



OPERATOR'S MANUAL
SFP9 | SFP40 PISTOL

Heckler & Koch is a leading firearms manufacturer of global proportions, yet remains firmly rooted in Germany. The company has been a dependable partner to security forces, police and special forces of NATO and its associated states for over 70 years.

Heckler & Koch stands for superlative quality and innovative products. Heckler & Koch is also the only small arm supplier with a comprehensive product portfolio. Its range includes pistols, submachine guns, assault rifles, designated marksman rifles, training systems and 40 mm systems.

QUALITY.
INNOVATION.
SERVICE.
SAFETY.

Thank you very much for deciding to purchase a product from Heckler & Koch.

The more familiar you are with the weapon, the safer you will be with it. Hence our request:

Read these operating instructions as well as the safety instructions they contain before operating the weapon. Keep the instruction manual for the life of the weapon and pass it on to any subsequent operator or owner, along with any supplements attached.

The weapon has been designed, manufactured and inspected according to the latest technical knowledge and the recognised safety-related technical rules and regulations. Nevertheless, use of the weapon may result in injury or death of the user and third parties, or damage to the weapon and other material property.

Please inform yourself with regard to the current edition of the safety instructions via www.heckler-koch.com.

 **DANGER**

Risk of death from gunshot wounds!

Accidental discharge of weapon may occur due to external influences when loaded weapon is handled.

- › Do not use the weapon until you have read and understood this manual completely.
- › Follow the safety instructions when handling the weapon.
- › Carry out a safety check before working on the weapon.

Table of contents

Part I	Description	
1	Using this manual	3
1.1	Purpose of this manual.....	3
1.2	Target audience for this manual.....	3
1.3	Safety instructions, notes and information.....	3
2	Safety instructions	7
2.1	Fundamental safety instructions	7
2.2	The operator's manual as an integral component of the safety concept.....	8
2.3	Safety instructions for handling the weapon	8
2.4	Safety instructions for firing.....	10
2.5	Safety instructions for utilising accessories and ammunition	10
2.6	Safety instructions for drop safety	11
2.7	Exclusion of liability and warranty.....	12
3	Description of the weapon	13
3.1	Intended use	14
3.2	Functional elements	14
3.3	Assembly groups	16
3.4	Safety features	17
4	Variants	20
4.1	Description of the features.....	20
4.2	Differences between trigger variants TR and SF	23
4.3	SFP9-TR – "Technical Specifications"	25
4.4	SFP9-SF SFP40-SF – "Special Forces"	25
4.5	SFP9 S SFP40 S – "Safety"	26
4.6	SFP9 SD SFP40 SD – "Silencer"	26
4.7	SFP9 SK – "Subcompact"	27
4.8	SFP9 L – "Long Slide"	27

4.9	SFP9 OR SFP40 OR – "Optic Ready"	28
4.10	SFP9 M SFP40 M – "Maritime"	29
4.11	Technical data	30
5	Cleaning kit and auxiliary materials	31
5.1	Cleaning kit	31
5.2	Cleaning kit	32
5.3	Auxiliary materials	33
Part II	Handling	
6	Checks	37
6.1	Carry out safety check.....	37
6.2	Carry out a function check	38
6.3	Inspect shaped spring for trigger bar	39
6.4	Checking function of the trigger safety	40
7	Preparations	41
7.1	Lock slide and let slide snap forwards	41
7.2	Adjust frame to hand	42
7.3	Attach lanyard	44
7.4	Using the safety flag	45
7.5	Adjust magazine catch pushbutton.....	46
7.6	Remove and insert front sight	49
7.7	Remove and insert rear sight	49
7.8	Change charging supports	50
7.9	Use red-dot sight with OR variants	51
7.10	Adjust rear sight	54
7.11	Using the weapon with a silencer.....	56
7.12	Fill the magazine	57
7.13	Prepare weapon for firing.....	59
7.14	Additional preparations in unusual climatic conditions	60

8	Operation	62
8.1	Insert magazine	62
8.2	Load weapon	62
8.3	Check whether there is a round in the chamber – "Chamber check"	63
8.4	Firing position and aiming	64
8.5	Firing	66
8.6	Remove magazine	67
8.7	Reload weapon	67
8.8	Unload weapon	68
8.9	Empty the magazine	68
9	Cleaning.....	69
9.1	General instructions for cleaning	69
9.2	Maintenance plan.....	70
9.3	Disassemble weapon.....	73
9.4	Remove and insert disassembly lever (with SK variants)	75
9.5	Clean weapon.....	76
9.6	Assemble weapon	82
10	Faults: Causes and remedies	86
11	Protection, packaging and storage	89
11.1	Protect the weapon.....	89
11.2	Package the weapon.....	89
11.3	Store the weapon	90
12	Transport and shipping	91
12.1	Prepare the weapon for transport.....	91
12.2	Transport and ship the weapon.....	91
13	Destruction and disposal.....	92
13.1	Destroy the weapon	92
13.2	Dispose of the weapon	92
	Index of keywords.....	93

PART I DESCRIPTION

1 Using this manual

This operator's manual describes all product variants and serial or special furnishings which are offered in the product family. For that reason, this operator's manual also describes and depicts equipment and functions which are not present on your weapon, e.g. due to the special furnishings selected.

Specific subjects can be found most quickly with the table of contents or index of keywords at the end of this operator's manual. For an overview of the weapon, it is recommended to see the first part ("Description") of this operator's manual.

1.1 Purpose of this manual

The first part of this manual ("Description") describes the design and function of the weapon, and the second part ("Handling") describes the handling of the weapon.

1.2 Target audience for this manual

This manual is intended for persons who are authorised to use this weapon. This manual does not assume extensive technical or weapons-specific knowledge.

1.3 Safety instructions, notes and information

To ensure the greatest possible safety during handling, important information and technical notes are specially highlighted.

1.3.1 Safety instructions and danger levels

Safety instructions are depicted as follows (example):

⚠ DANGER

Risk of death from gunshot wounds!







Accidental discharge of weapon may occur due to external influences when loaded weapon is handled.

- › Do not use the weapon until you have read and understood this manual completely.
- › Follow the safety instructions when handling the weapon.
- › Carry out a safety check before working on the weapon.

The following colours and signal words are used in the safety instructions to indicate various danger levels:

Colour / signal word	Meaning
⚠ DANGER	Direct, imminent danger! Non-compliance will lead to death or extremely serious injury.
⚠ WARNING	Possible imminent danger! Non-compliance could lead to death or serious injury.
⚠ CAUTION	Dangerous situation! Non-compliance could lead to minor injuries.
NOTICE	Non-compliance could lead to material damage.

1.3.2 Symbols used

Symbol	Meaning
	Here you have to observe something.
	Supplementary information regarding weapon and accessories.
	Tip / useful hint
1. / 1.	Call to perform an action in a sequence of actions: Here you have to do something!
>	Stand-alone call to perform an action or call to perform an action in a safety instructions: Here you have to do something!
▶	Cross reference between individual sections: Open to the relevant page and follow the section described there! The sections can be found most quickly with the index of keywords at the end of this manual.
•	Bullet point
	Call to perform an action properly implemented. The check was successful.
	Call to perform an action improperly implemented. The check was not successful: Follow the specified call to perform an action!
	Here something engages.

1.3.3 Conventions for illustrations



Details in illustrations can - depending on the variant - deviate from your current weapon and/or the accessories.

The information “right,” “left,” “front” and “rear” refers to the position of the weapon and/or accessories as viewed from the direction of fire.

Illustrations and their constituent elements are identified as follows:

- Components relevant to the action are highlighted in blue. Where necessary the components are marked with numbers and identified in a legend.
- Motions are indicated by orange-coloured arrows.
- Calls to perform an action are indicated by upper-case letters enclosed in circles.

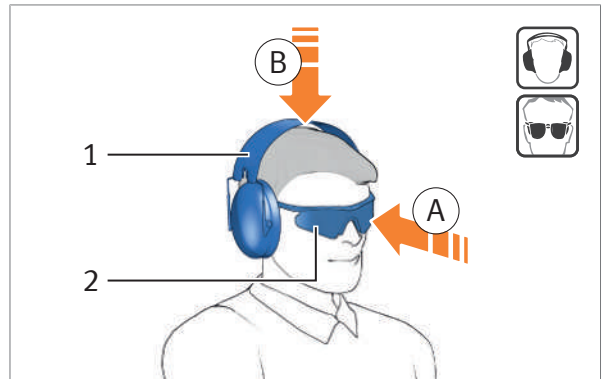

Fig. 1: Example of an illustration

- 1 Hearing protection
- 2 Safety goggles

1.3.4 Conventions for cross references



Cross references represent relationships between the text and an illustration or an individual section.

- Cross references between text and illustrations are in *italics* and enclosed in (brackets), e.g. (Fig. 1).
- Cross reference between individual sections are marked with the symbol ► (Fig. 2).

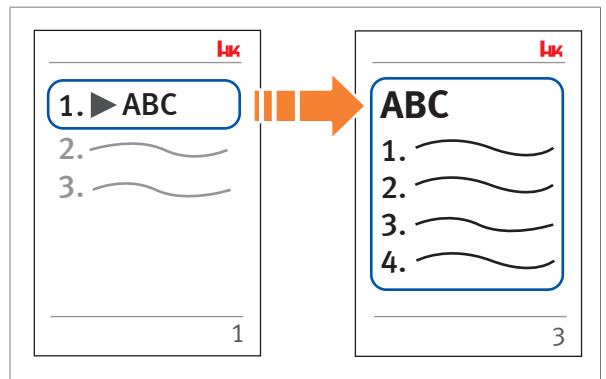

Fig. 2: Example of a cross reference between sections

2 Safety instructions

2.1 Fundamental safety instructions



The weapon has been designed, manufactured and proofed according to the latest technical knowledge and the recognised safety rules. Nevertheless, use of the weapon may result in injury or death of the user and third parties, or damage to the weapon and other material property.

Please inform yourself with regard to the current edition of the safety instructions via www.heckler-koch.com.

- › Follow all of the instructions in this operator's manual. Non-compliance may result in injury or death.
- › Never handle the weapon if you are tired, feeling unwell, or when you have previously consumed alcohol, drugs or any types of medicines.
- › Always follow the instructions provided by their respective manufacturers when using accessories and ammunition.
- › Always follow the safety data sheets and details or instructions from the respective manufacturers when using hazardous materials, such as e.g. oils, lubricants and cleaning agents.
- › Always follow all valid provisions for handling weapons, accessories and ammunition.
- › Always follow all valid provisions for handling hazardous materials, such as e.g. oils, lubricants and cleaning agents.

2.2 The operator's manual as an integral component of the safety concept



The operator's manual is an integral component of the weapon.

- › Do not use the weapon until you have read and understood this operator's manual completely.
- › Always adhere to the stated sequence for handling stages in the operator's manual.
- › Keep the operator's manual for the entire service life of the weapon.
- › Please inform yourself with regard to the current edition of the operator's manual, safety instructions and any relevant supplements via www.heckler-koch.com.
- › If you receive any supplements or amendments, be sure to add them to the operator's manual.
- › Always pass the operator's manual and the enclosed supplements on to any subsequent operator or owner.

2.3 Safety instructions for handling the weapon

- › Special care must be taken when handling firearms, because the position and direction of the weapon can be changed very easily.
- › Use the weapon only for its intended purpose. Do not use the weapon as a club, hammer, pry bar, etc. Using the weapon for other than its intended purpose may result in accidental discharge of weapon or damage to the weapon.
- › Until you have performed a safety check, treat the weapon as if it was loaded and the safety released.
- › Use the weapon only if it is in perfect technical condition.
- › Do not play with the weapon.

2.3.1 Handling

- › Never point the weapon at people when handling or practising with it.
- › Make sure that the weapon is always unloaded when it is handled for purposes other than loading or firing.
- › Do not touch the trigger when loading, unloading, aiming, disengaging the safety or handling the weapon in any other way.
- › Always place your trigger finger on the outside of the trigger guard.
- › Do not use excessive force when handling, disassembling, cleaning and assembling the weapon.

2.3.2 Safety features

- › Do not rely on safety features. Safety features are no substitute for careful, correct handling of the weapon.
- › For weapons with safety lever, make sure that the safety lever is always clicked to the "Safe" position.

2.3.3 Malfunctions and unusual encumbrances



Users are strictly prohibited from troubleshooting faults that go beyond the scope of this manual! Only authorised specialists may rectify faults in the weapon.

- › Always treat the weapon as if it were loaded in the event of a malfunction.
- › Immediately rectify any faults that compromise safety.
- › Exposure to exceptional stresses such as when the weapon is banged or dropped can have a negative effect on safety. After exceptional stresses, have the weapon inspected by the manufacturer or trained firearms personnel.

2.3.4 Handing over the weapon

- › Do not entrust the weapon to anyone who has not comprehensively read and completely understood this operator's manual.
- › Do not entrust the weapon to anyone who is not entitled to possess the weapon. Observe applicable regulations.
- › Never handover or receive the weapon unless it is unloaded and the slide is in the open position.

2.3.5 Storage, transport and disposal

- › Store weapon and ammunition separately. Be sure to prevent access to the weapon and ammunition by unauthorised persons, especially children.
- › Always follow the applicable provisions for the transport and shipping of weapons and ammunition.
- › Always follow the applicable provisions for destroying and disposal of weapons and ammunition.

2.3.6 Additional information

- › Always prevent dry firing of the hammer with weapons with a hammer sidelock. Dry firing of the hammer can lead to premature wear.
- › Always prevent dry firing of the firing pin with weapons with a firing pin lock. Dry firing of the firing pin can lead to premature wear.
- › Always prevent snapping forward of the bolt group with rapid firing weapons such as e.g. machine guns. Snapping forwards of the bolt group can lead to premature wear.

2.4 Safety instructions for firing

- › Wear hearing protection when firing.
- › Wear safety goggles when firing.
- › Keep the muzzle area clear when firing.
- › Wear protective gloves when touching the barrel or parts which heat up during firing after firing.
- › Use only properly loaded, undamaged cartridges of the correct calibre.
- › Do not shoot at doors, panes of glass, walls, concrete, stone, or smooth surfaces (including water). A bullet can penetrate these objects or be deflected in an unsafe direction.
- › Pull the trigger only if the weapon is pointing at the target and the area behind the target is not endangered.
- › The trigger must be pulled back completely when firing. The trigger must be released completely and return to the forward position after every shot when firing in rapid succession.
- › Only actuate the trigger after you have snapped the safety lever into the desired firing selection position.
- › Keep your hands out of the slide when firing.

2.5 Safety instructions for utilising accessories and ammunition

- › Inspect the attachments mounted on the weapon for secure seating before firing and at regular intervals.
- › Use only properly loaded, undamaged cartridges of the correct calibre.
- › The use of muzzle attachments such as silencers or blank firing attachments places greater stress on the weapon and gets it dirty faster. Clean the weapon at shorter intervals.
- › Only mount attachments on the Picatinny rail when their weight does not exceed a maximum of 160 g. Mounting heavier attachments will impair safe functioning and may damage the weapon.
- › Only mount rear sights with a maximum weight of 54 g on the adapter plates of “Optic Ready” variants.
- › Only use ammunition which corresponds to the specifications of the C.I.P. or SAAMI standardisation organisations.
- › Do not use +P+ ammunition. Excessive gas pressure cause increased wear and can damage the weapon.

2.6 Safety instructions for drop safety



Drop safety is affected by many factors, such as: fall height, fall angle, ground, type and frequency of impact, handling and treatment of the weapon, loading and safety status of the weapon, accessories and equipment configuration of the weapon and the ammunition used. Regardless of the weapon's manufacturer or model, absolute drop safety is not possible and can only be checked based on defined test parameters.



Use of weapons with match/sporting trigger: For physical reasons, match/sporting triggers have reduced drop and impact safety due to the refined trigger characteristics. Extraordinary stresses, such as if the weapon falls and hits the floor, can cause an accidental discharge.

- › Make sure that the weapon is always unloaded when it is handled for purposes other than loading or firing.
- › Always ensure, with weapons with a safety lever, that the safety lever is in the desired firing selection position immediately before firing.
- › Set the safety lever to the “Safe” position during every pause in firing.
- › Use a carrying sling / securing belt in order to prevent the weapon from falling and striking the ground.
- › After exceptional stresses, such as falling and hitting the ground, have the weapon inspected by trained firearms personnel.

2.7 Exclusion of liability and warranty

Heckler & Koch GmbH accepts no liability and provides no warranty for incidents arising from:

- non-compliance with this manual,
- incorrect handling of the weapon,
- negligence,
- improper use,
- use of +P+ ammunition,
- modifications, attachments to or conversion of the weapon without the express written consent of Heckler & Koch GmbH, or
- use of accessories or spare parts from other manufacturers without the express written consent of Heckler & Koch GmbH (except for accessories from other manufacturers mentioned in this manual).

3 Description of the weapon

The modern SFP (Strike Fire Pistol) is a fully pre-cocked system with single-action trigger and is available as the SFP9 in calibre 9 mm x 19 and as the SFP40 in calibre .40 S&W.

The pistol's standard features include unique characteristics and innovative details. Patented charging supports in the rear slide area, enabling a secure grip to prevent injuries when cocking the weapon.

The disassembly process requires no tools and guides the user through a mandatory course of action, offering maximum safety to prevent accidents. The weapon cannot be disassembled unless the magazine has been removed. Unlike comparable models of pistols, the weapon automatically de-cocks itself when disassembled. In addition, the trigger need not be pulled before disassembly.



Fig. 3: SFP9

The magazine and ergonomics concept of the P30 were transferred to the new series of pistols. Interchangeable back straps and grip shells also provide this model with various combination options for individual grip shape.

Its excellent trigger characteristics promote maximum accuracy during rapid fire sequences. It is based on a well-balanced relationship between hand position, light trigger pull and short trigger travel and reset.

All SFP pistols are optionally available with "TG" trigger according to the "Pistols in Calibre 9 mm x 19" Technical Guideline or with a short SF "Special Forces" trigger.

The SFP family of pistols provides versatile equipment and individualisation options which can be selected depending on mission requirements or the shooter's preferences.

The SFP series of pistols uses magazines from the HK P30 pistol model. This eliminates extra logistical considerations for units using a mixture of SFP9 and P30 pistols.

3.1 Intended use

The SFP9 | SFP40 pistol is a hand-gun for engaging targets at a range of up to 50 m.

3.2 Functional elements

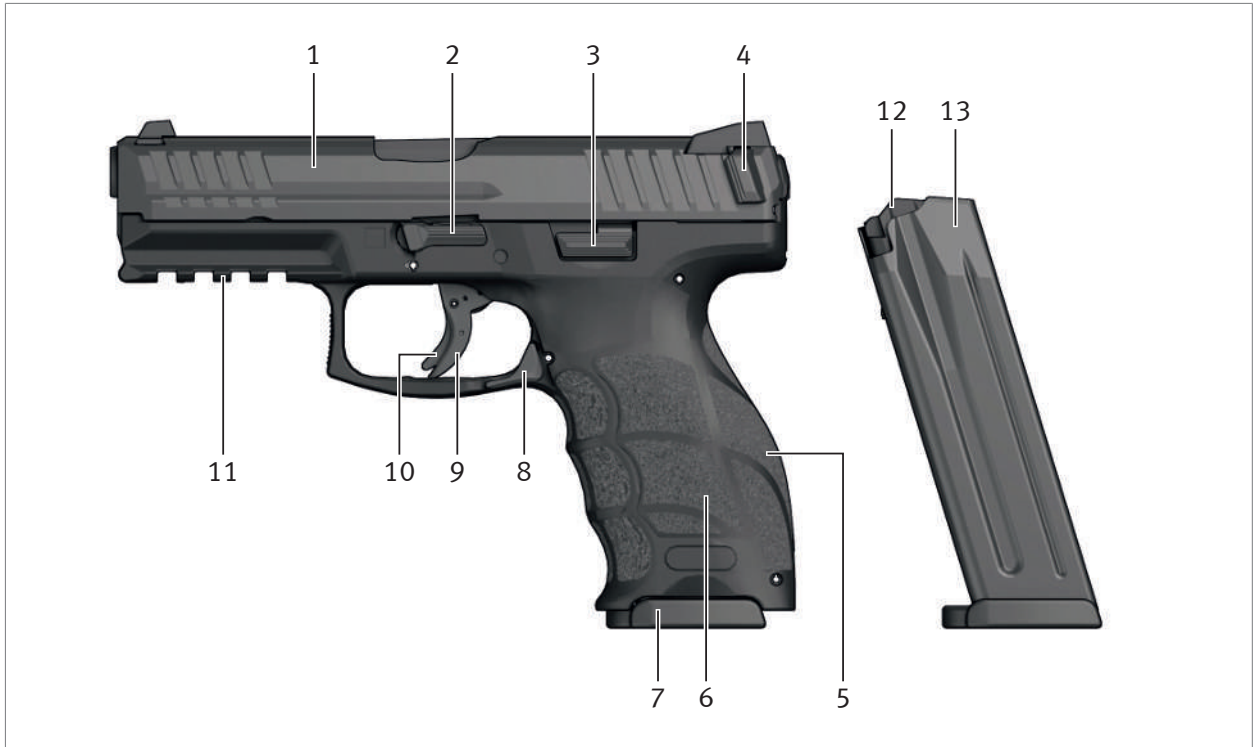

Fig. 4: Left side view

- | | | | |
|---|--------------------------------|----|----------------|
| 1 | Slide | 8 | Magazine catch |
| 2 | Disassembly lever | 9 | Trigger |
| 3 | Slide release, left | 10 | Trigger safety |
| 4 | Charging support, ambidextrous | 11 | Picatinny rail |
| 5 | Back strap | 12 | Follower |
| 6 | Grip shell, left | 13 | Magazine lips |
| 7 | Magazine | | |



Fig. 5: Right side view

- | | | | |
|---|----------------------|----|----------------------------|
| 1 | Rear sight | 6 | Front sight |
| 2 | Slide release, right | 7 | Trigger guard |
| 3 | Extractor | 8 | Frame |
| 4 | Serial number | 9 | Grip shell, right |
| 5 | Barrel | 10 | Mounting point for lanyard |

3.3 Assembly groups



Fig. 6: Assembly groups

1 Slide

2 Barrel

3 Recoil spring

4 Frame

5 Magazine

3.4 Safety features

3.4.1 Trigger safety

The trigger safety prevents the trigger from being released accidentally if the weapon is dropped, for instance. The trigger safety blocks the trigger and thus prevents the cocked firing pin from being released. Only when the trigger safety is squeezed completely does the trigger safety release the trigger.

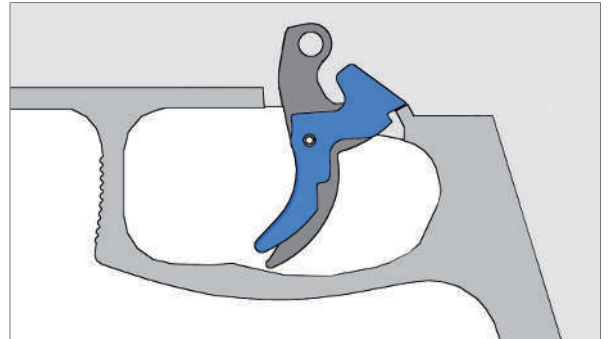

Fig. 7: Trigger safety

3.4.2 Firing pin safety

The firing pin safety prevents the firing pin from being able to strike the cartridge primer in the event of an accidental discharge, for instance if the weapon is dropped. The firing pin remains blocked until the trigger is pulled.

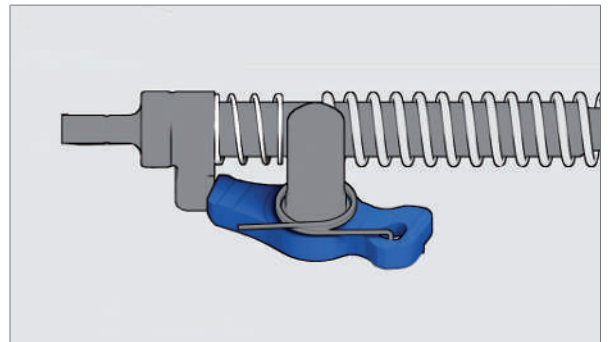

Fig. 8: Firing pin safety

3.4.3 Disassembly safety

The disassembly safety mechanism prevents a cartridge from being in the chamber while the weapon is being disassembled. The disassembly lever is blocked by the magazine and slide. The disassembly lever cannot be operated until the magazine is removed and the slide is locked. Removing the magazine ensures that a cartridge cannot be fed into the chamber. If there is a cartridge in the chamber, the cartridge will be ejected when the slide is pulled back. Consequently there can be no round in the chamber when the weapon is disassembled into assembly groups. The firing pin is not cocked when the slide is being disassembled and the trigger must not be pulled.

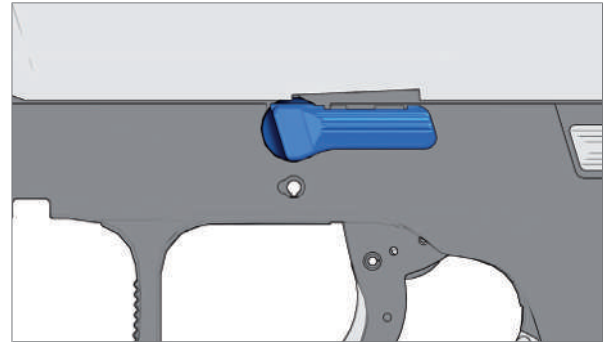

Fig. 9: Disassembly safety

3.4.4 Operator safety

The operator safety ensures that the weapon cannot be fired until the slide is in the locked position. If the slide is in an unlocked position, the disconnecter breaks the connection between trigger bar and firing pin. The disconnecter does not release the trigger bar until the slide is in a locked position.

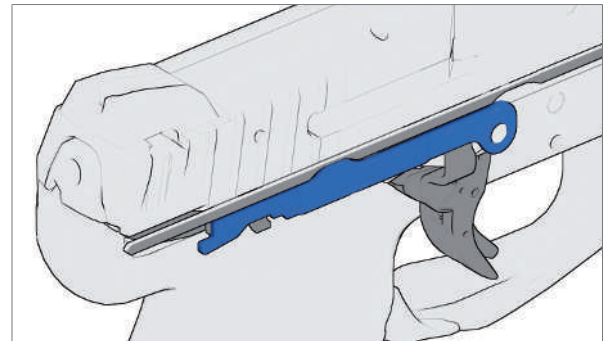

Fig. 10: Operator safety

3.4.5 Loaded chamber indicator

The red marking on the extractor indicates whether or not there is a cartridge in the chamber.

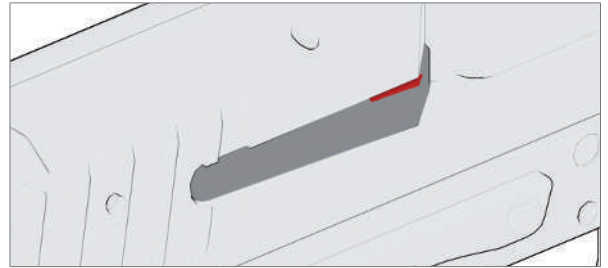

Fig. 11: Loaded chamber indicator

3.4.6 Firing pin cocking indicator

The red marking on the back of the firing pin indicates whether or not the firing pin is cocked.

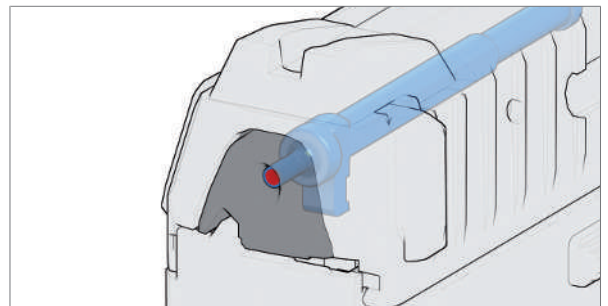

Fig. 12: Firing pin cocking indicator

3.4.7 Safety lever

The safety lever prevents accidental actuation of the trigger. In the “S” position (Fig. 13) the trigger is blocked. Only when the safety lever is clicked to the “F” position (Fig. 14) the trigger can be pulled.

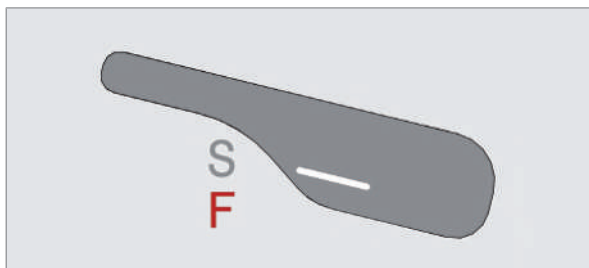

Fig. 13: “S” position

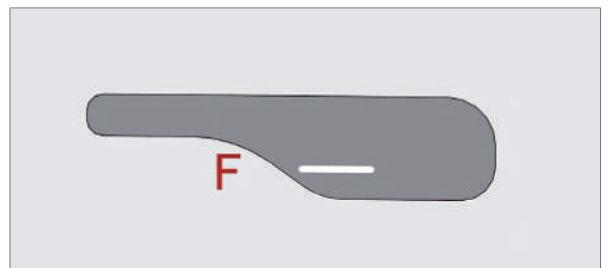



Fig. 14: “F” position









4 Variants

4.1 Description of the features

4.1.1 Features for the product groups

Illustration	Feature	Information
 <p>9 mm</p>	9 mm x 19 calibre	<p>The variants called SFP9 are available in 9 x 19 mm calibre.</p> <p>The special 9 mm x 21 calibre is possible.</p>
 <p>.40 S&W</p>	.40 S&W calibre	<p>The variants called SFP40 are available in .40 S&W calibre.</p>

4.1.2 Features for the variants

Illustration	Feature	Information
	TR trigger	The trigger pull, trigger travel and return travel of the TR trigger variant conform to the requirements of the Technical Specification for Pistols of the German police.
	SF trigger	The SF (Special Forces) trigger variant has a lighter trigger pull and shorter trigger travel and return travel in comparison with the trigger variant TR.
	Silencer	The barrel has an interface for mounting a silencer. The sights are adapted for the use of a silencer.
	Mount for red dot sight	The slide is equipped with an interface for mounting a red dot sight. A cover plate is mounted as standard.
	Subcompact	This variant has a smaller frame, a shorter barrel and a shorter slide.
	Long-Slide	This variant has a longer slide and longer barrel.
	Safety lever	The frame has an ambidextrous safety lever to safe the weapon manually.
	Special coating	The weapon has a special coating for maritime use.

4.1.3 Optional features



The features described in this section are available for all variants.

Illustration	Feature	Information
	Trigger variant	The weapon is available with a TR trigger or SF trigger.
	Colour	The standard colour of the weapon is black. Other colours such as RAL8000 - green brown are possible.
	Transponder	As an option the frame may contain a transponder for recording weapon-specific data.
	Charging supports	The charging supports can be personalized. Multiple sizes are available.
	Grip shells / back strap	The grip can be personalized. The size L of the back straps and grip shells is supplied as standard. Other sizes are available.
	Magazine capacity	Different magazines with different magazine capacities are available for the respective pistol variants.
	Magazine catch	The ambidextrous magazine catch is available as rocker or push button. The push button can be switched for use by right-handed or left-handed shooters.
	Push Button	The Push Button magazine catch can be individually adjusted. Numerous dimensions are available.

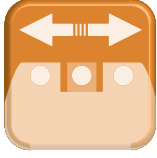
Illustration	Feature	Information
	Sights	The standard sights consist of a rectangular rear notch and a post front sight with self-illuminating contrast dots. Further variants are possible, such as an adjustable rectangular rear notch without contrast points.

4.2 Differences between trigger variants TR and SF

The trigger pull, trigger travel and return travel of the TR trigger variant conform to the requirements of the Technical Specification for Pistols of the German police.

Trigger variant	TR	SF
Trigger pull	30+5 N (TR requirement: min. 30 N)	22+5 N
Travel up to let-off point	approx. 11 mm (TR requirement: 10 - 15 mm)	approx. 6 mm
Return travel until re-triggering is possible	approx. 5 mm (TR requirement: min. 4 mm)	approx. 3 mm



Risk of mistaking SF and TR parts: Make sure not to mix up the frames or slides of trigger variants TR and SF during assembly.

For instance, if an SF frame is assembled with a TR slide, the weapon's functioning and drop safety will no longer be ensured. Parts of the weapon may be damaged. It may no longer be possible to disassemble the weapon.



You can recognise the trigger variant of your weapon by the trigger bar in the frame and by the firing pin safety in the bolt group.

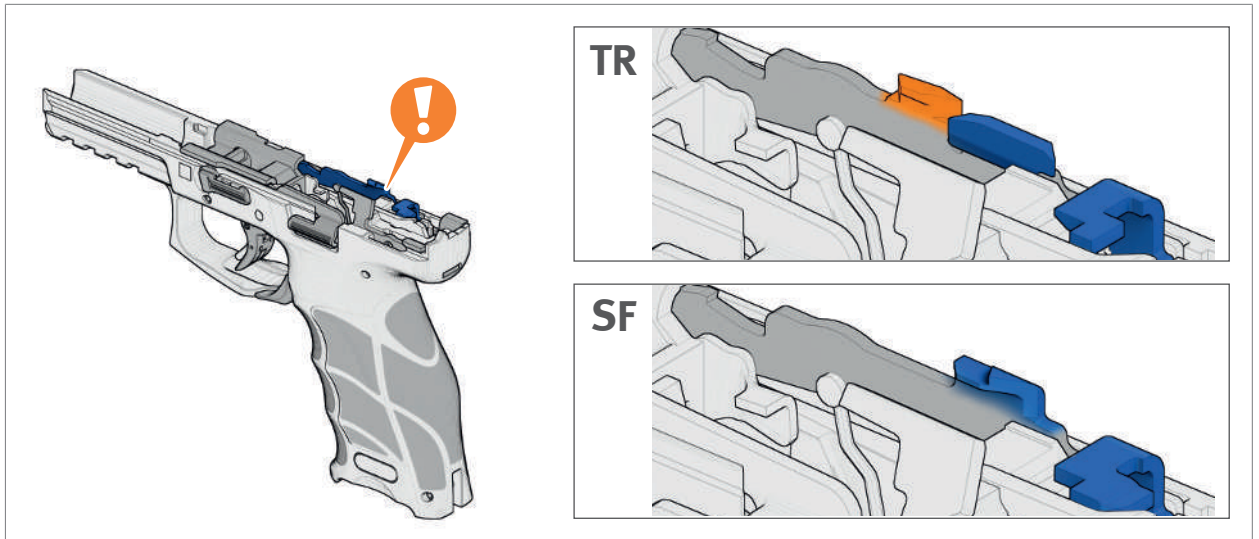

Fig. 15: Trigger bar in frame

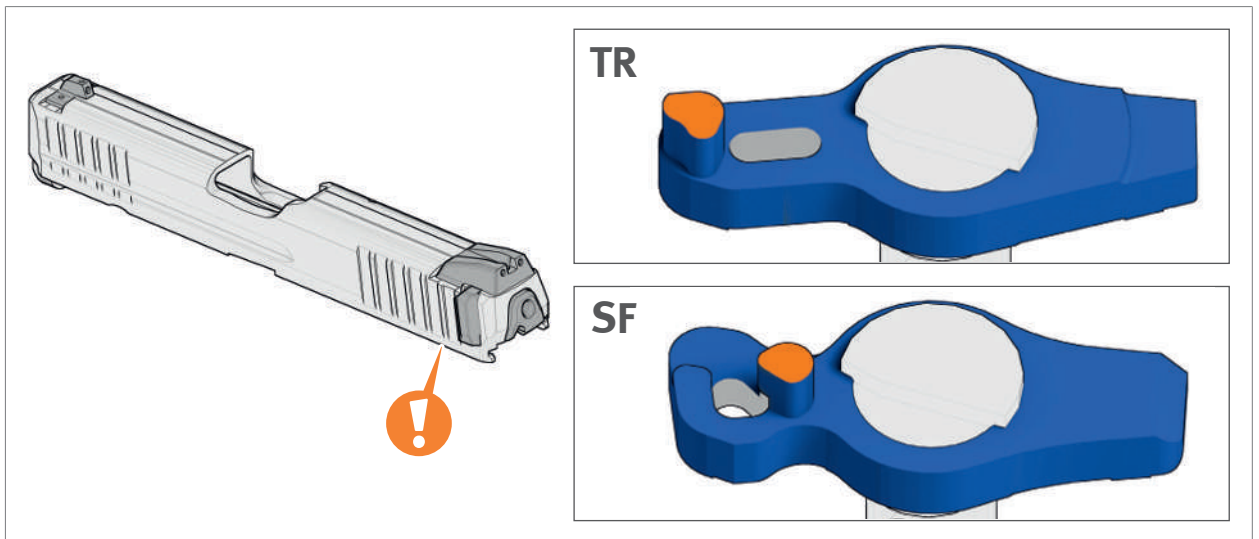

Fig. 16: Firing pin safety in slide

4.3 SFP9-TR – "Technical Specifications"

Police version certified in accordance with the Technical Specifications (TR).



4.4 SFP9-SF | SFP40-SF – "Special Forces"

"Special Forces" version with reduced trigger pull as well as shorter trigger and return travel compared to the TR version.



4.5 SFP9 S | SFP40 S – "Safety"

"Safety" version with ambidextrous safety lever for manually setting the weapon to safety.



4.6 SFP9 SD | SFP40 SD – "Silencer"

"Silencer" version with threaded barrel and match sights for silencer application.



4.7 SFP9 SK – "Subcompact"

"Subcompact" version with small frame, short barrel and short slide. Suitable for concealed carrying method.



4.8 SFP9 L – "Long Slide"

"Long Slide" version with longer barrel (127 mm / 5") and longer slide. The 5" barrel and long sight radius enable optimal accuracy.



4.9 SFP9 OR | SFP40 OR – "Optic Ready"

"Optic Ready" version with interface for mounting a red dot sight. A cover plate is mounted as a standard feature. Various adapter plates are available for mounting conventional compact sights.



The red dot sights are shown as an example. No guarantee is made for models other than the ones specified. The maximum permissible weight of the red dot sight which may be mounted is 54 g.

Red dot sight		Adapter plate
Burris FastFire 2	01	
Burris FastFire 3	01	
C-More STS 2	03	
Docter Sight III	01	
Insight MRDS	01	
Leupold DeltaPoint Pro	04	
Meopta MeoSight III	01	
Trijicon RMR	02	
Vortex Venom	05	
Vortex Viper	05	

4.10 SFP9 M | SFP40 M – "Maritime"

"Maritime" version with special coating for maritime missions.

- Special saltwater-resistant coating (weapon fully useable according to the NATO salt spray test and NATO long-term saltwater test as per AC225 requirements).
- Maritime corrosion protection.
- Parts fully compatible for exchanging with non-maritime SFP models.



4.11 Technical data

4.11.1 Dimensions [mm]

SFP9 / SFP40	SK	TR	SF	M	S	OR	SD	L
Length	168		186		186	186	202	210
Width	33		33		40	33	33	33
Height	116		138		138	138	138	138
Barrel length	86		104		104	104	119	127
Sight radius	145		162		162	162	162	183

4.11.2 Weights [g]

SFP9 / SFP40	SK	TR	SF	M	S	OR	SD	L
SFP9 with magazine	687		710		719	723	719	760
SFP40 with magazine	744		820		829	833	829	--
Magazine, empty	75		93		93	93	93	93

4.11.3 Other data

SFP9 / SFP40		SK	TR	SF	M	S	OR	SD	L
v_0 [m/s]	9 mm ₁	345		360		360	360	375	385
	.40 S&W ₂	285		295		295	295	310	--
E_0 [J]	9 mm ₁	480		518		518	518	562	590
	.40 S&W ₂	471		505		505	505	560	--

₁ RUAG Ammotec (SX) Sintox Standard ammunition, calibre 9 mm x 19

₂ Remington UMC 180 gr. ammunition, .40 S&W calibre

5 Cleaning kit and auxiliary materials



The cleaning kit is not included in the standard scope of supply for the weapon. The cleaning kit can be ordered from Heckler & Koch using the Ident.-No. shown.

5.1 Cleaning kit



Fig. 17: cleaning kit (Ident.-No. 988426)

- | | | | |
|---|----------------------------|---|-----------------------|
| 1 | container for cleaning kit | 5 | pull-through holder |
| 2 | handle rod | 6 | wool pull through |
| 3 | extension rod | 7 | oil brush |
| 4 | oil bottle | 8 | barrel cleaning brush |

5.2 Cleaning kit

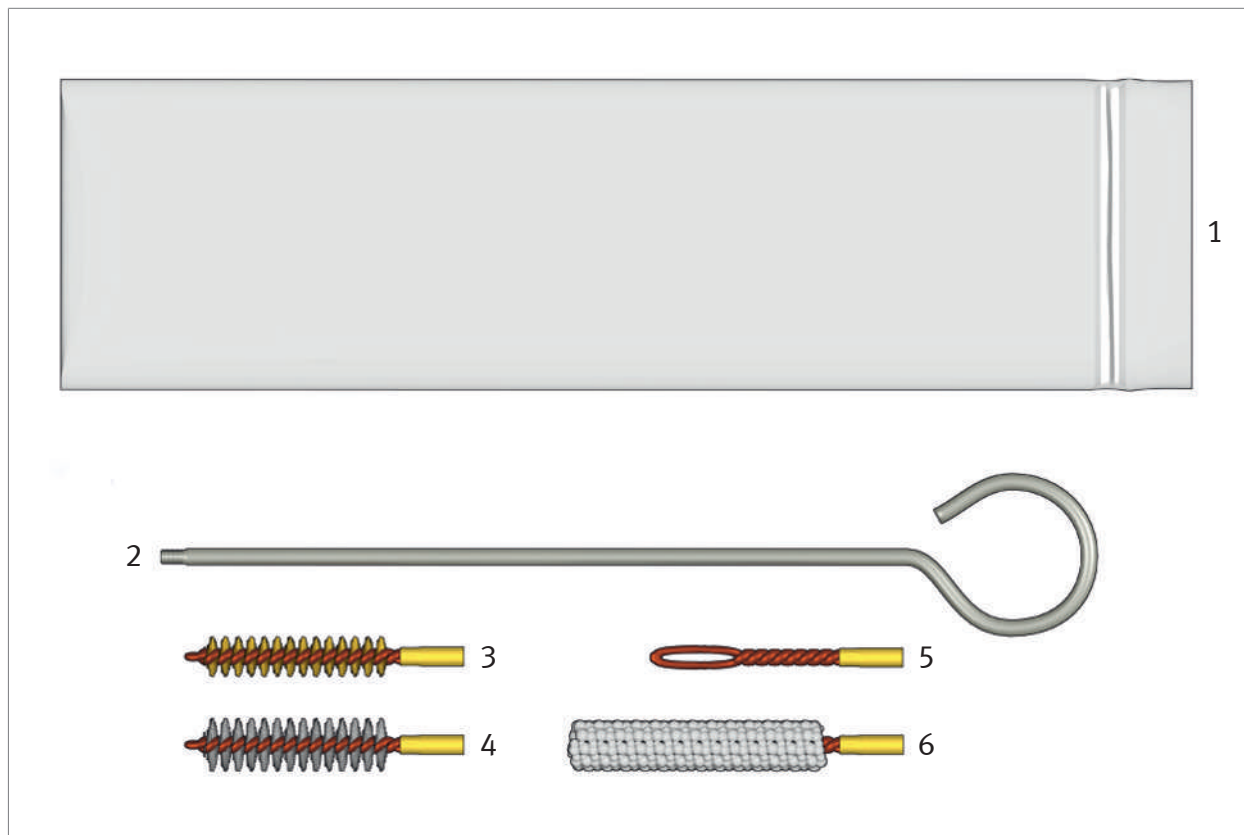

Fig. 18: cleaning kit (Ident.-No. 987837)

- | | | | |
|---|-----------------------|---|---------------------|
| 1 | Bag | 4 | oil brush |
| 2 | handle rod | 5 | pull-through holder |
| 3 | barrel cleaning brush | 6 | wool pull through |

5.3 Auxiliary materials



Auxiliary materials are available from specialist dealers.

Required auxiliary materials are listed at the beginning of each section.

5.3.1 Tools

- Ø 1.8 mm pin punch (Ident.-No. 957310)
- Ø 2.8 mm pin punch (Ident.-No. 957312)
- Tool for Push Button (only with versions with Push Button magazine catch)
- Adjustment tool
- Tool made of unhardened steel
- Hammer, 200 g (Ident.-No. 957416)
- Vice
- Protective jaws

5.3.2 Torque wrench and employment



A suitable torque wrench and socket set are available in specialist shops.

Activity	Torque	Assignment
Insert cover plate <i>only for "Optic Ready" version</i>	2 Nm	Torx insert TX15
Assemble adapter plate <i>only for "Optic Ready" version</i>	2 Nm	Torx insert TX15

5.3.3 Lubricants / Other auxiliary materials

- Low-temperature oil (MIL-L-14107), e.g. O-157
- Oil (MIL-L-63460), e.g. S-761
- Grease
- Oil paper
- Cleaning rag (lint-free)
- Cleaning pull-throughs
- Bottle cleaning brush (min. Ø 20 mm)
- Detergent

6 Checks

6.1 Carry out safety check



Successful completion of a safety check verifies that there is no ammunition in the weapon. The safety check is especially important when accepting a weapon and when you are unsure whether or not a weapon is loaded.

1. ▶ Remove the magazine.
2. ▶ Lock slide.
3. Look into the chamber (*Fig. 19*). There must not be a cartridge in the chamber. If there is a cartridge in the chamber, then a fault is present. ▶ Faults: Causes and remedies.
4. ▶ Let slide snap forwards.
5. For variants with safety lever, click safety lever to the "S" position.

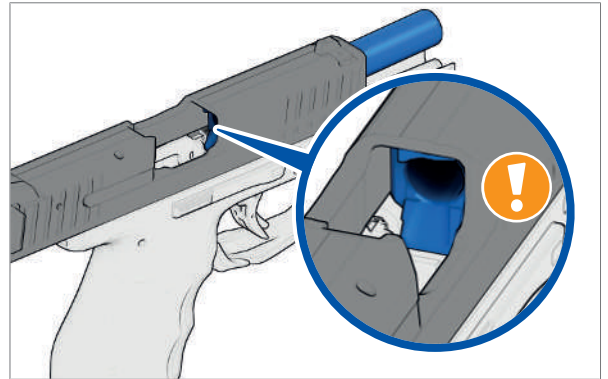

Fig. 19: Look into the chamber

6.2 Carry out a function check



Successful completion of a function check verifies that the weapon is functional. The function check is especially important after assembly of the weapon and after rectification of faults.

1. ► Carry out a safety check.
2. Insert empty magazine into the weapon until the magazine catch engages.
3. Verify that magazine is firmly seated.
4. Pull slide all the way back. The slide release holds the slide in the open position.
5. ► Let slide snap forwards. The firing pin was cocked.
6. ► Remove the magazine.
7. Pull trigger. The firing pin is released. For variants with safety lever: The firing pin is not released.
8. Click safety lever to the "F" position.
9. Pull trigger. The firing pin is released.
10. Click safety lever to the "S" position.

6.3 Inspect shaped spring for trigger bar



The successful execution of a function check verifies that the weapon is functional. Inspecting the shaped spring is particularly necessary after cleaning and assembling the weapon.

1. ► Carry out a safety check.
2. Pull slide to the rear and hold it.
3. ► Let slide snap forwards. The firing pin is cocked.
4. For variants with safety lever, click safety lever to the "F" position.
5. Pull trigger.



The firing pin is released. The red marking on the firing pin is no longer visible through the window in the slide plate.



The firing pin is not released. The red marking on the firing pin is visible through the window in the slide plate.

1. Send weapon in for repair.

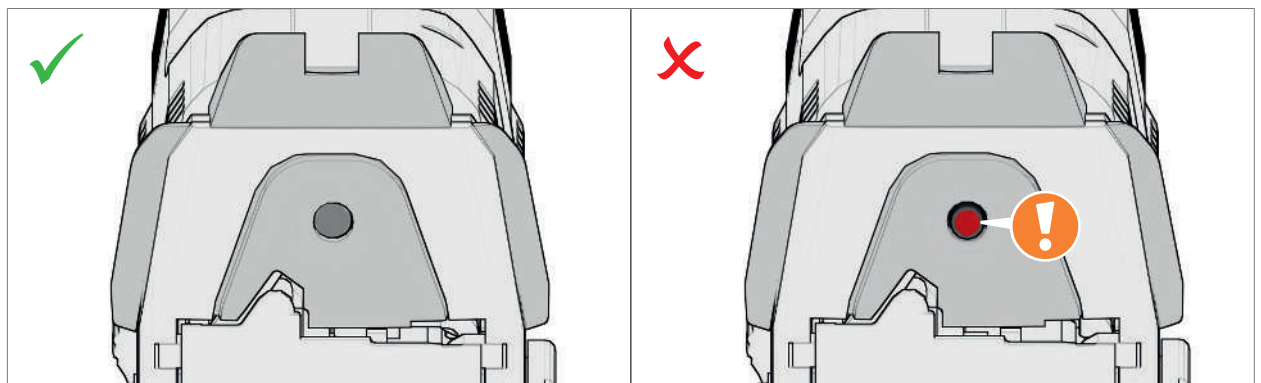

Fig. 20: Firing pin cocking indicator

6.4 Checking function of the trigger safety

1. Push trigger towards the rear, but do not actuate the trigger safety when doing so (Fig. 21).



The trigger is blocked.

2. Push trigger safety and trigger towards the rear (Fig. 22).



The trigger is not blocked.

3. Let the trigger and trigger safety move forward.



The trigger safety protrudes markedly.



If one of the checks is not successful:

1. Send weapon in for repair.

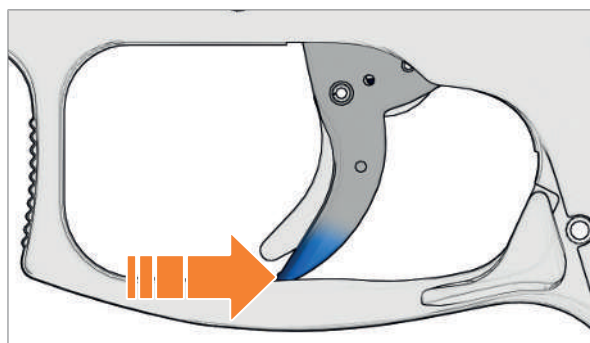

Fig. 21: Push trigger towards the rear

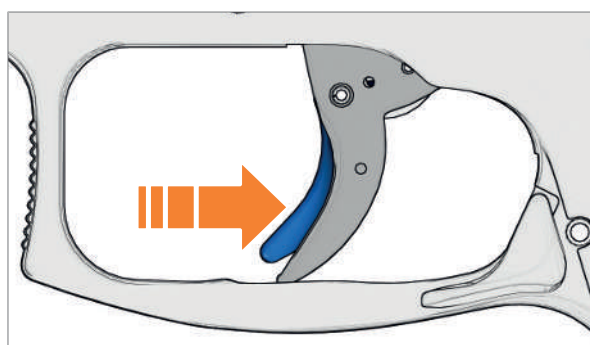

Fig. 22: Push trigger safety towards the rear

7 Preparations

7.1 Lock slide and let slide snap forwards

7.1.1 Lock slide

1. Pull slide all the way back and hold it there (*Fig. 23*).
2. Press slide release upwards to lock slide (*Fig. 23*).

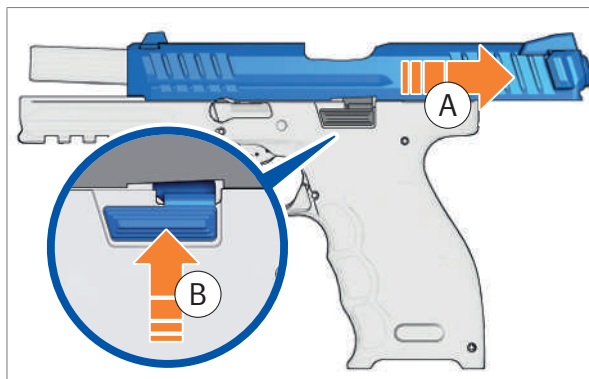

Fig. 23: Lock slide

7.1.2 Let slide snap forwards

CAUTION

Risk of injury when the slide snaps forwards!

The slide snaps forwards when slide release is pushed.

- › Do not reach into the path of the slide.
- › Press slide release downwards (*Fig. 24*). The slide snaps forwards.

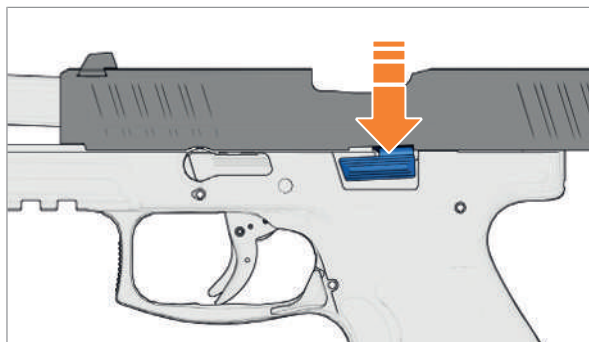

Fig. 24: Press slide release downwards

7.2 Adjust frame to hand



The exchangeable back straps and grip shells allow an ergonomically optimal hand position for any hand size. To adjust the frame, the grip shells and the back strap that do not fit have to be removed and grip shells and a back strap that fit installed.

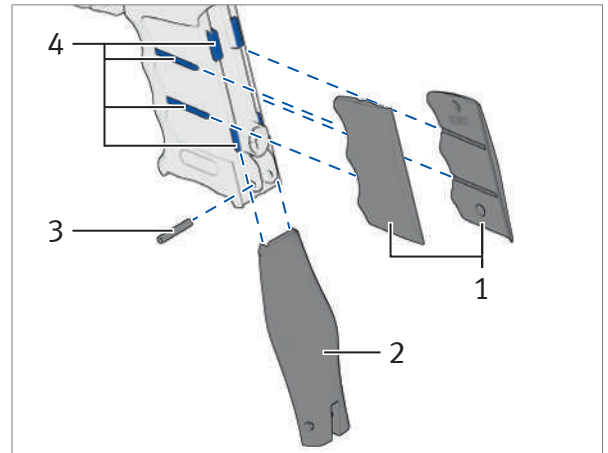

Fig. 25: Back strap and grip shells

- 1 Grip shell
- 2 Back strap
- 3 Clamping sleeve for back strap
- 4 Guides on frame

7.2.1 Disassemble grip shells and back strap

Required auxiliary materials:

- Ø 2.8 mm pin punch
- Hammer

1. Extract clamping sleeve for back strap using pin punch (Fig. 26).
2. Push back strap downwards and remove.
3. Push left grip shell and right grip shell to the rear and remove.

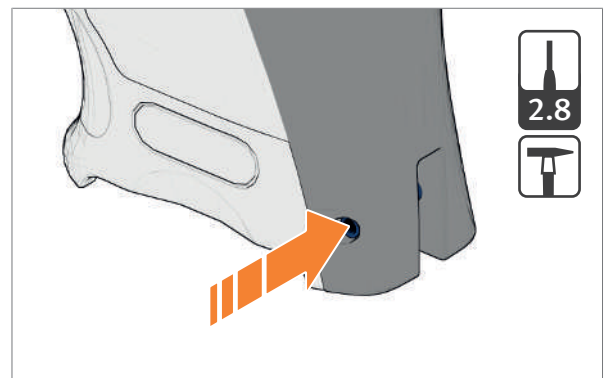

Fig. 26: Drive out clamping sleeve for back strap

7.2.2 Assemble grip shells and back strap

Required auxiliary materials:

- Ø 2.8 mm pin punch
- Hammer

NOTICE

Risk of damage to polymer guides!

Use of excessive force when assembling grip shells and back strap can damage the polymer guides.

- › Push grip shells forward into polymer guides on frame.
- › Do not use excessive force when assembling the grip shells and back strap.



Improperly assembled grip shells can cause malfunctions. Make sure after assembling the grip shells that there is no gap between frame and grip shell.

1. Slide grip shells into the plastic guides of the frame from rear to front (Fig. 27).
2. Place back strap from the rear onto the guides on the frame and push upwards.
3. Drive in clamping sleeve for back strap using pin punch.

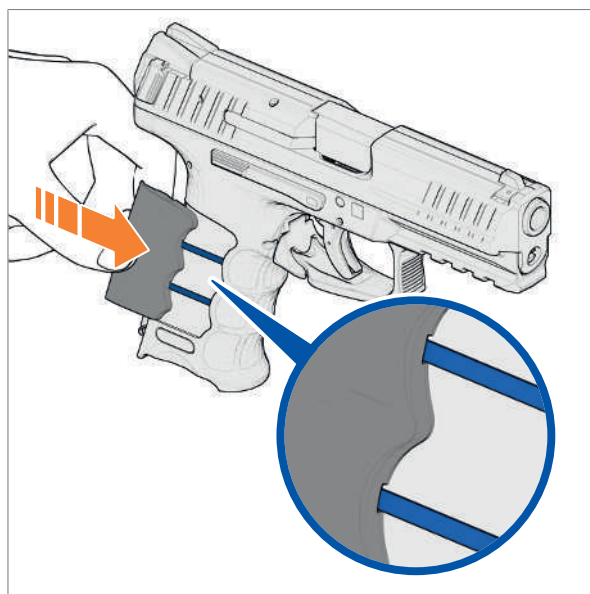

Fig. 27: Slide grip shells into guides

7.3 Attach lanyard



A lanyard can be attached to the frame. The lanyard connects the weapon to the shooter and secures the weapon to prevent it from being lost, falling and striking the ground.

Required auxiliary materials:

- Ø 2.8 mm pin punch
- Hammer

1. Driving out clamping sleeve for back strap (Fig. 28).
2. Insert the mounting for the lanyard (Fig. 29).
3. Drive in clamping sleeve for back strap (Fig. 29).
4. Secure the lanyard on the mounting.

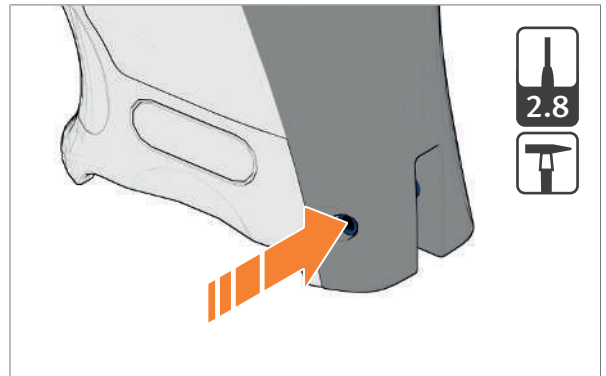

Fig. 28: Driving out clamping sleeve for back strap

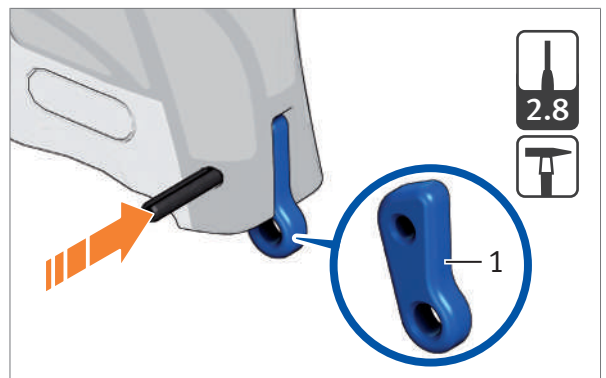

Fig. 29: Insert the mounting for the lanyard

- 1 Mounting for the lanyard (Ident.-No. 250729)

7.4 Using the safety flag



The safety flag in the chamber indicates that there is no cartridge in the chamber. The slide is set back relative to the frame. This prevents the firing pin from being caught by the hammer catch and the main spring is released.

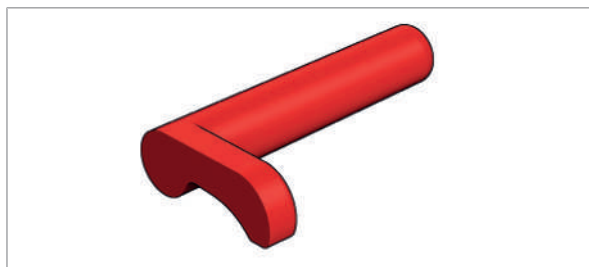

Fig. 30: Safety flag

7.4.1 Insert safety flag

1. ► Carrying out a safety check.
2. ► Lock slide into place.
3. Insert safety flag into chamber (Fig. 31).
4. Pull slide back and move it forwards slowly.

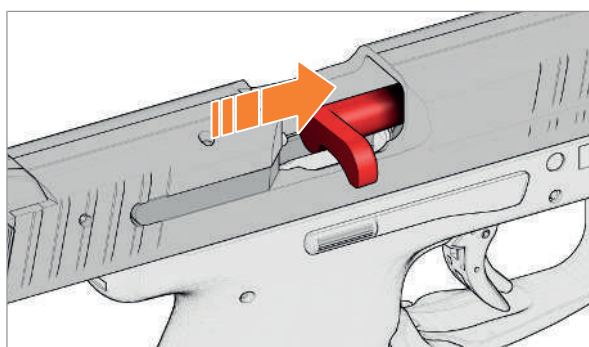

Fig. 31: Insert safety flag

7.4.2 Remove safety flag

1. ► Lock slide into place.
2. Remove safety flag.
3. Pull slide back and move it forwards.

7.5 Adjust magazine catch pushbutton



The exchangeable pushbutton enables an ergonomically optimal operation of the magazine catch. The pushbutton is available in various sizes.



Heckler and Koch recommends using the tool for the pushbutton for converting the magazine catch.

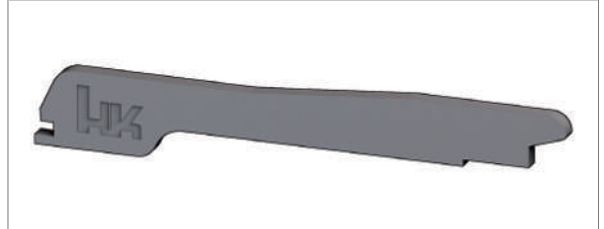

Fig. 32: Tool for pushbutton (Ident.-No. 253579)

NOTICE

Risk caused by inadvertent actuation of the magazine catch!

Due to the firing position and utilising a pushbutton which is too large, the magazine catch can be inadvertently actuated when shooting.

- › Always inspect before firing for whether the pushbutton is coordinated for your firing position.
- › Utilise a smaller pushbutton dimension when necessary.

7.5.1 Disassemble magazine catch

Required auxiliary materials:

- Tool for pushbutton
- \varnothing 1.8 mm pin punch
- Hammer

1. ► Disassemble weapon.
2. In case of weapons with clamping sleeve for magazine catch: Drive out clamping sleeve with pin punch (Fig. 33).
3. Push the latching clip in the frame forwards with the tool and then push the magazine catch upwards (Fig. 34). The magazine catch latches in.
4. Remove pushbutton (Fig. 34).

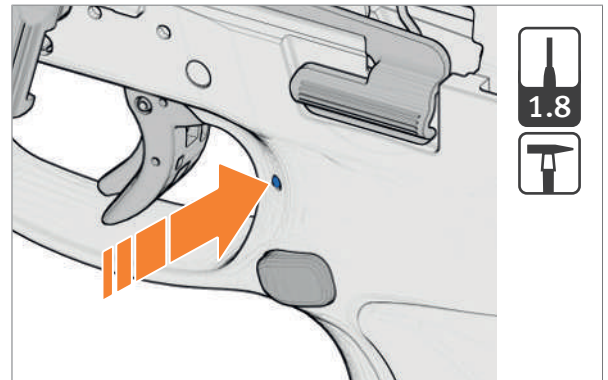

Fig. 33: Driving out clamping sleeve

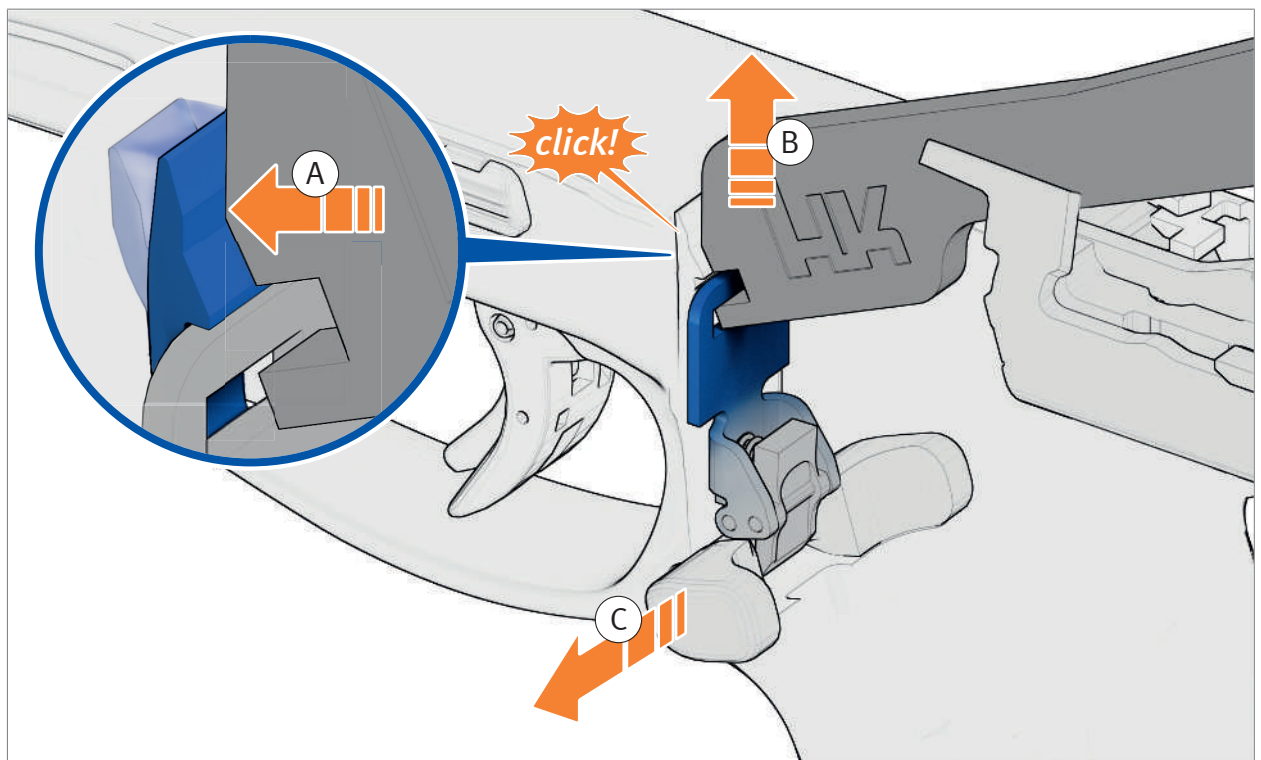

Fig. 34: Remove pushbutton

7.5.2 Assemble magazine catch

Required auxiliary materials:

- Tool for pushbutton
- Ø 1.8 mm pin punch
- Hammer

1. ► Disassemble magazine catch.
2. Convert pushbutton (Fig. 35).
3. Insert pushbutton (Fig. 35).
4. Press the detent piece on the magazine catch with the tool and hold it down (Fig. 36).
5. Push the magazine catch downwards until the magazine catch latches (Fig. 36).
6. In case of weapons with clamping sleeve for magazine catch: Drive in clamping sleeve.
7. ► Assemble the weapon.

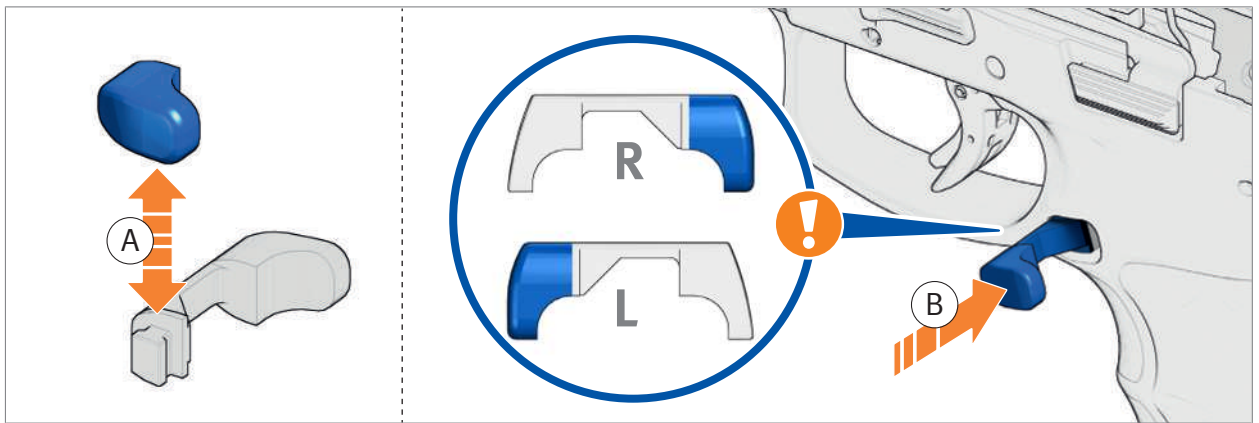

Fig. 35: Convert pushbutton

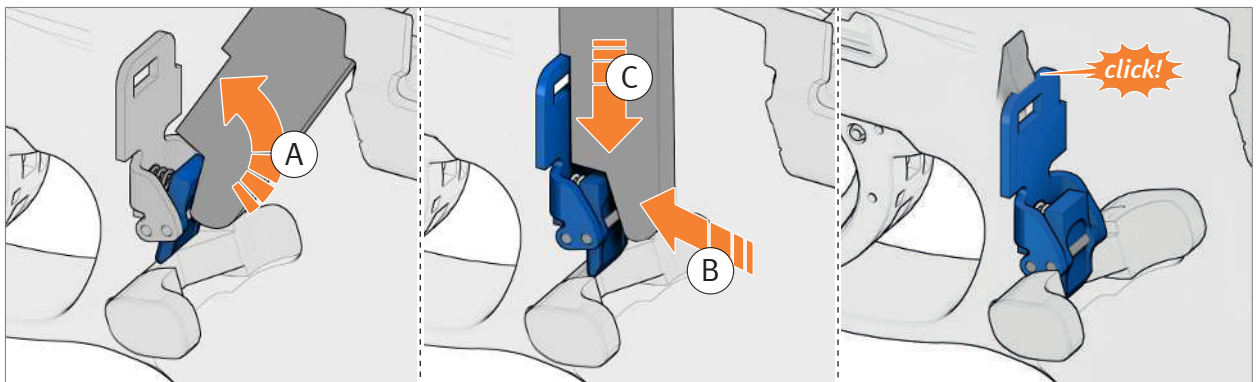

Fig. 36: Latch in the magazine catch

7.6 Remove and insert front sight

Required auxiliary materials:

- Hammer
- Tool made of unhardened steel
- Vice
- Protective jaws

1. Insert protective jaws.
2. Clamp slide in vice.
3. Remove front sight with tool (*Fig. 37*).
4. Insert front sight with tool

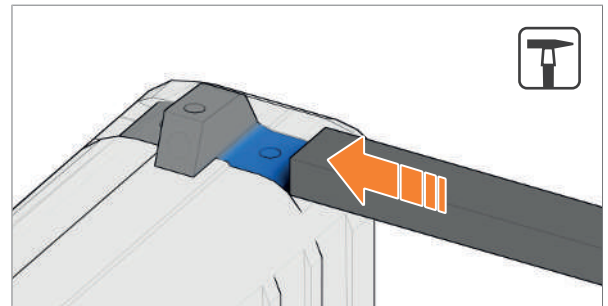

Fig. 37: Remove front sight

7.7 Remove and insert rear sight

Required auxiliary materials:

- Hammer
- Tool made of unhardened steel
- Vice
- Protective jaws

1. Insert protective jaws.
2. Clamp slide in vice.
3. Remove rear sight with tool (*Fig. 38*).
4. Remove rear sight with tool

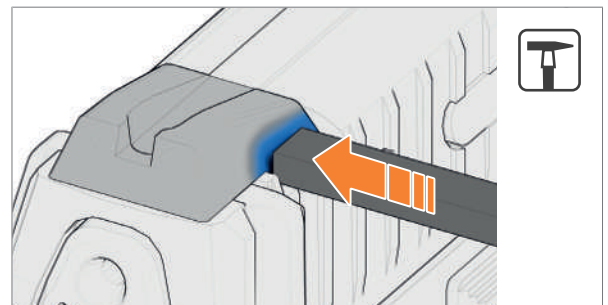

Fig. 38: Removing rear sight

7.8 Change charging supports



The charging supports allow ergonomically optimal operation of the slide. The charging supports come in various sizes.

1. ▶ Remove rear sight.
2. Remove charging supports (*Fig. 39*).
3. Insert other charging supports.
4. ▶ Insert rear sight.

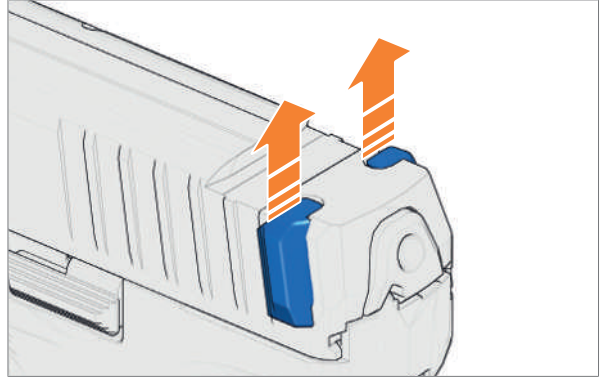

Fig. 39: Remove charging supports

7.9 Use red-dot sight with OR variants



Observe the operator's manual specifications from the respective manufacturer.



Use suitable screws (M4 x 8) of quality class 12.9 with screw locking to secure the adapter plate. The screws can be ordered from Heckler & Koch using the Ident.-No. 255747.



Observe the specified torque using a suitable torque wrench when tightening the screws. Heckler & Koch recommends to have the insertion of the adapter plates and the tightening of the screws conducted by a specialised dealer.

WARNING

Risk of injury from red dot sight tearing off!

If the total of rounds fired is high and the specified torque is not complied with, the adapter plate screws could break and the red dot sight could be flung rearwards by the movement of the slide.

- › Replace the adapter plate screws with new screws of the same quality class with screw lock after 2,000 rounds.

7.9.1 Remove cover plate

Required auxiliary materials:

- Torque wrench 2 - 10 Nm
- Torx insert TX15

1. Adjust torque wrench.
2. Loosen screws and remove them (Fig. 40).
3. Remove cover plate.

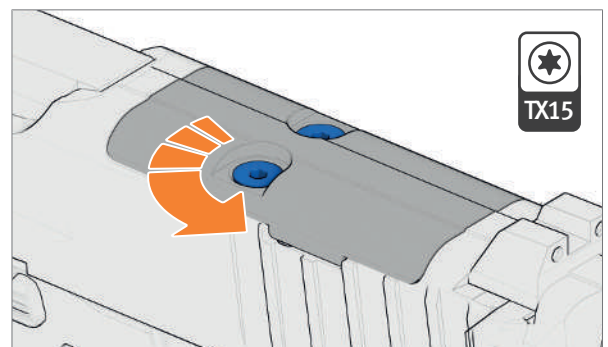

Fig. 40: Loosen screws

7.9.2 Insert cover plate

Required auxiliary materials:

- Torque wrench 2 - 10 Nm
- Torx insert TX15

1. Adjust torque wrench.
2. Insert cover plate in slide.
3. Insert screws in cover plate.



Observe the torque when tightening the screws.

4. Tighten screws until the torque is reached (*Fig. 41*).

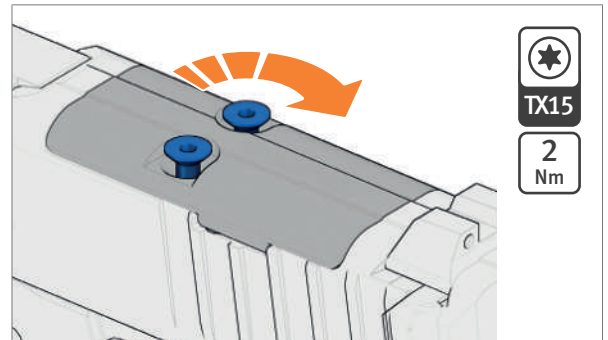

Fig. 41: Tighten screws

7.9.3 Assemble the adapter plate and the red dot sight

Required auxiliary materials:

- Torque wrench 2 - 10 Nm
- Torx insert TX15

1. ► Remove cover plate.
2. Adjust torque wrench.
3. Place suitable adapter plate on mounting for adapter plate.
4. Insert screws into adapter plate.



Observe the torque when tightening the screws.

5. Tighten screws until the torque is reached (Fig. 43).
6. Place red dot sight on the adapter plate.
7. Insert screws in the red dot sight.
8. Tightening the screws

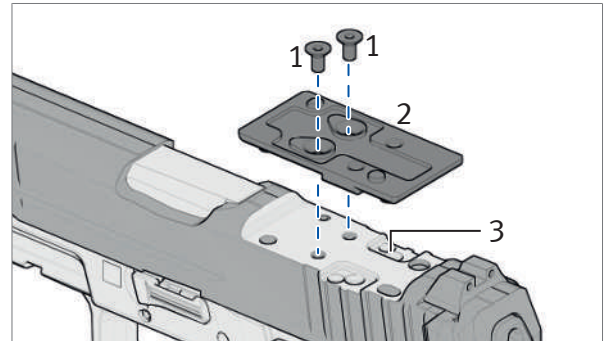

Fig. 42: Adapter plate

- 1 Screws M4 x 8 mm (2x)
- 2 Adapter plate
- 3 Mounting for adapter plate

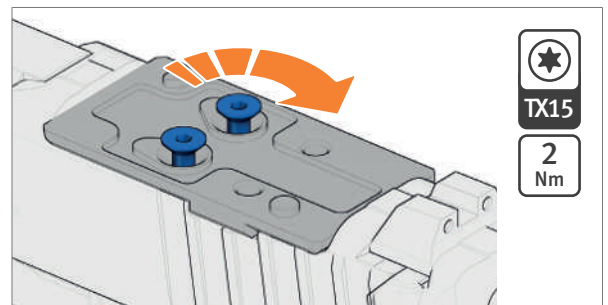

Fig. 43: Tighten screws

7.10 Adjust rear sight



The position of point of impact also depends on the ammunition. Use of different types of ammunition can change the elevation and windage of the position of point of impact. The sights can be adjusted to correct the changed position of point of impact.

7.10.1 Adjust adjustable rear sight

Required auxiliary materials:

- Adjustment tool

Position of point of impact	Corrective measures	Information
	› Turn elevation adjustment screw clockwise with adjustment tool (Fig. 44).	Turning by a quarter revolution changes the point of impact by approx. 4.5 cm at a range of 25 m.
	› Turn elevation adjustment screw anti-clockwise with adjustment tool (Fig. 44).	
	› Turn windage adjustment screw clockwise with adjustment tool (Fig. 45).	Turning by a half revolution changes the point of impact by approx. 3 cm at a range of 25 m.
	› Turn windage adjustment screw anti-clockwise with adjustment tool (Fig. 45).	

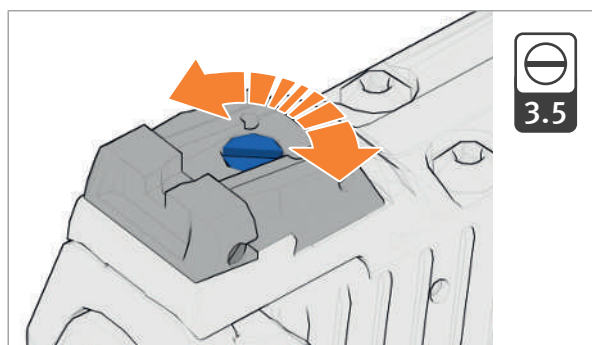

Fig. 44: Turn elevation adjustment screw

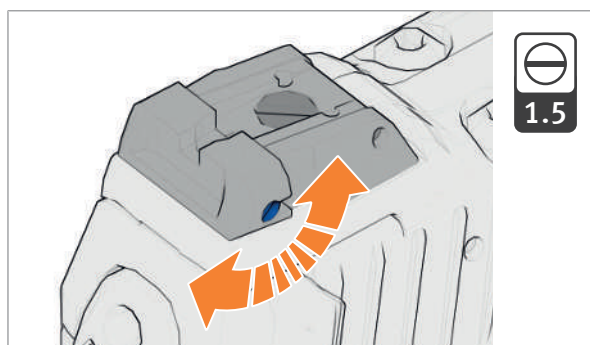

Fig. 45: Turn windage adjustment screw

7.10.2 Adjust standard sights



There are numerous front sight heights and two sight heights available. The height of the front sight is engraved on the underside of the front sight. The sight with the greater sight height is identified by a round mark on the top side.

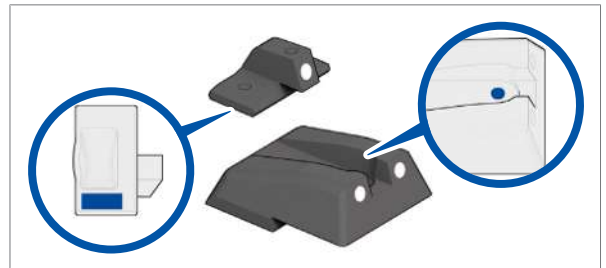

Fig. 46: Component marking for the sights

Required auxiliary materials:

- Hammer
- Tool made of unhardened steel

Position of point of impact	Corrective measures	Information
	<ol style="list-style-type: none"> 1. ► Remove front sight or rear sight. 2. Insert front sights with larger sight heights or rear sights with lower sight heights with tool. 	Changing the front sight height / rear sight height by 0.2 mm changes the point of impact by approx. 3 cm to 25 m range.
	<ol style="list-style-type: none"> 1. ► Remove front sight or rear sight. 2. Insert front sights with lower sight heights or rear sights with larger sight heights with tool. 	
	<ol style="list-style-type: none"> 1. Shift rear sight to the right using the tool (Fig. 47). 2. If necessary, also shift the front sight to the left (Fig. 48). 	Lateral shifting of rear sight or front sight by 0.2 mm changes the point of impact by approx. 3 cm to 25 m range.
	<ol style="list-style-type: none"> 1. Shift rear sight to the left using the tool (Fig. 47). 2. If necessary, also shift the front sight to the right (Fig. 48). 	

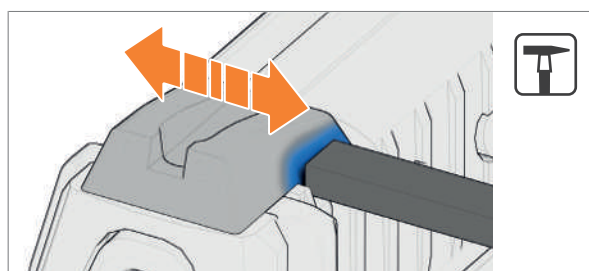

Fig. 47: Shift rear sight laterally

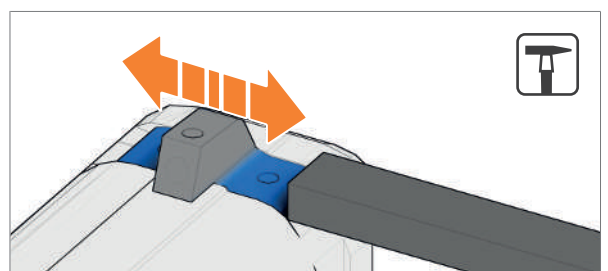

Fig. 48: Shifting the front sight laterally

7.11 Using the weapon with a silencer



Observe the operator's manual specifications from the respective manufacturer.



Firing with a silencer places greater stress on the weapon and thus contributes to faster wear and heavier fouling. If the weapon is used with a silencer, the weapon and the silencer must be cleaned every time it is fired and at intervals of 120 rounds and lubricated more heavily.



The silencer may loosen itself depending on the silencer version and the total of rounds fired. Inspect the silencer for secure seating before firing and at regular intervals.

CAUTION

Risk of injury from hot silencer!

The silencer heats up during firing.

- › Let silencer cool off for at least 15 minutes after firing.
- › Wear protective gloves when touching the silencer after firing.



The barrel has a standard M13.5 x 1 LH thread on the muzzle for mounting a silencer.

1. Insert silencer
2. Remove the silencer after firing with a silencer.
3. Clean silencer.

7.12 Fill the magazine



The contents of the magazine can be checked via holes in the rear of the magazine.

NOTICE

Risk of material damage due to damaged or fouled cartridges!

Damaged or fouled cartridges can damage the weapon and cause malfunctions.

› Do not use damaged or fouled cartridges.

NOTICE

Risk of material damage from an overfilled magazine!

An overfilled magazine can lead to malfunctions.

› Only fill the magazine with the permissible number of cartridges.

NOTICE

Risk of material damage from keeping a magazine filled for long periods!

Keeping a magazine filled for long periods can result in damage to the magazine spring and cause malfunctions.

› Empty the magazine before placing the weapon and magazine in storage.

7.12.1 Fill magazine without a loading aid

1. Grasp the magazine.
2. Push cartridge under the magazine lips (Fig. 49).
3. Push cartridge to the rear as far as it will go (Fig. 49).
4. Repeat steps 2. - 3. until the magazine is full.

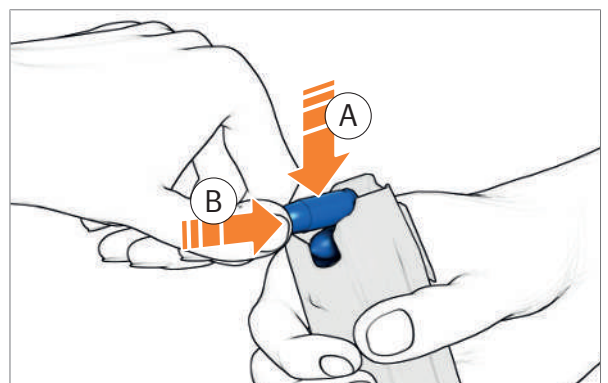

Fig. 49: Fill the magazine

7.12.2 Fill magazine with a loading aid



The loading aid is not included in the standard scope of supply for the weapon. The loading aid can be ordered from Heckler & Koch using the Ident.-No. shown.

1. Place loading aid on magazine (Fig. 50).
2. Press loading aid downwards and hold it (Fig. 51).
3. Push cartridge base forwards under the magazine lips (Fig. 51).
4. Lift loading aid (Fig. 52).
5. Push cartridge all the way to the rear (Fig. 52).
6. Repeat steps 2. - 5. until the magazine is filled.

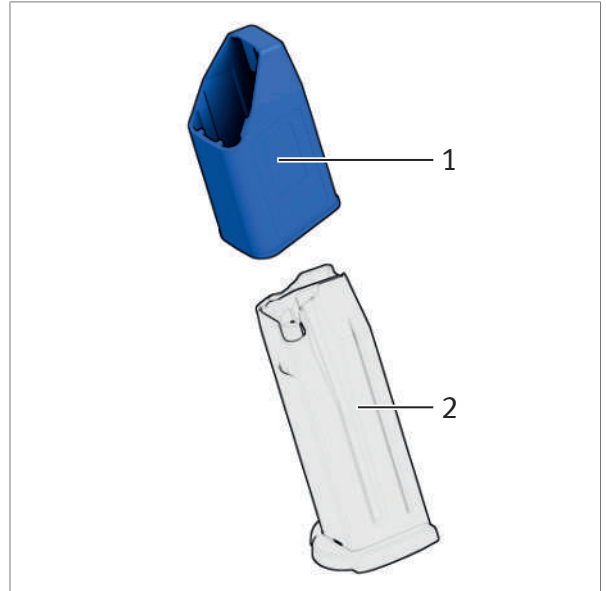

Fig. 50: Place loading aid on magazine

- 1 Loading aid (Ident.-No. 217830)
- 2 Magazine

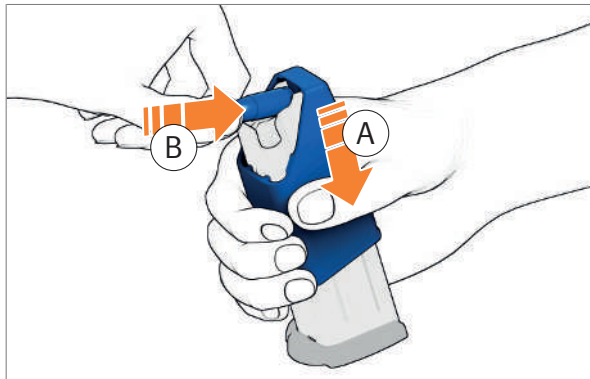

Fig. 51: Pushing cartridge under the magazine lips

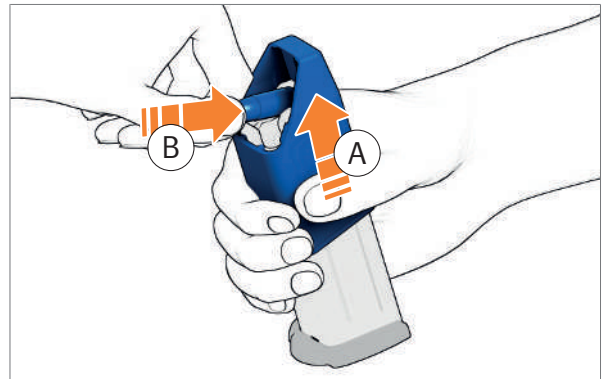

Fig. 52: Pushing cartridge to the rear

7.13 Prepare weapon for firing

Required auxiliary materials:

- *Cleaning kit*
- *Cleaning pull-throughs*

1. ► Disassemble weapon.
2. Screw handle rod, extension rod(s) and pull-through holder together.
3. Insert clean cleaning pull-throughs in pull-through holder.

NOTICE

Risk of material damage from incorrect cleaning direction!

Cleaning the barrel from the muzzle end may damage the muzzle. A damaged muzzle will decrease the weapon's accuracy.

› Always clean the barrel starting from the chamber end.

4. Pull clean cleaning pull-throughs through the barrel several times until the barrel, chamber and cartridge guide are free of oil and foreign bodies (*Fig. 53*).
5. Visually check weapon for damage.
6. ► Assemble the weapon.
7. ► Carry out a function check.

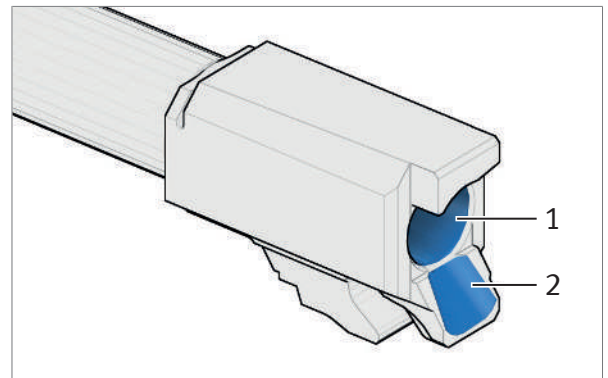

Fig. 53: Clean and oil barrel, chamber and cartridge guide

- 1 Chamber
- 2 Cartridge guide

7.14 Additional preparations in unusual climatic conditions



The following environmental effects require additional measures to maintain operability:

- Extreme dryness and heavy dust formation
 - Extreme heat
 - Moisture and mud
 - Saltwater and salty air
 - Extreme cold (under -25°C) and snow
-

7.14.1 Extreme dryness and heavy dust formation

- › Test the free movement of all moving parts of the weapon. Clean and oil if stiff.
- › Lubricate the weapon more heavily in case of extreme dryness or heavy dust concentration.
- › Protect magazine from dust (sealable magazine pouch).
- › Store ammunition in dust-tight containers.
- › Do not oil ammunition. Remove dirt and dust particles before use.

7.14.2 Extreme heat

- › Lubricate the weapon more heavily at temperatures over +63°C.
- › Only touch metal parts with gloves (danger of burns).
- › Protect ammunition from direct sunlight and heat.

7.14.3 Moisture and mud

- › Lubricate weapon more heavily.
- › Protect weapon from moisture and mud.
- › After contact with mud, wash the weapon off with fresh water, dry it and lubricate it.

7.14.4 Saltwater and salty air



Make sure that steel parts without protective coating are lubricated.

- › In case of salty air and saltwater, lubricate all moving parts of the weapon with low-temperature oil.
- › After contact with saltwater or salt spray, wash the weapon off with fresh water, dry it and lubricate it.
- › Store the weapon in a dry container so that it is protected from saltwater and salty air.

7.14.5 Extreme cold (under -25°C) and snow



In cold conditions, freezing condensation can compromise the functional reliability of the weapon. To prevent the formation of condensation, do not bring the weapon from cold conditions into warm conditions and shortly thereafter again into cold conditions.

- › At temperatures below -25°C, lubricate all moving parts with low-temperature oil.
- › Clean and dry weapon thoroughly before lubricating it with low-temperature oil.
- › Only touch metal parts with gloves (danger of frostbite).
- › Before loading, carry out a function check and ensure that the moving parts move freely.
- › Thaw frozen parts of the weapon and ice in the barrel with heated low-temperature oil.
- › To store the weapon, lubricate all moving, friction and sliding surfaces more heavily.
- › Store the weapon in dry, unheated rooms.

8 Operation

8.1 Insert magazine

1. ► Fill magazine.
2. Insert filled magazine into the weapon until the magazine catch engages.

8.2 Load weapon

⚠ WARNING

Risk of injury from accidental discharge of weapon!
A loaded weapon is always a potential source of danger.

- › Load the weapon only immediately before firing.
- › Unload the weapon immediately after firing.

1. ► Insert the magazine.
2. Pull slide all the way back and let it snap forwards. The weapon has a round in the chamber.



After the weapon is loaded the firing pin is cocked.



The firing pin may decock after exceptional stresses, such as the weapon falling. Check the firing pin cocking indicator. Chamber another round if necessary. Have the weapon inspected by trained firearms personnel after use.

8.3 Check whether there is a round in the chamber – "Chamber check"



Conduct this check immediately after shooting if you are not sure whether there is a round in the chamber.



If the weapon is dirty, it may happen that the force of the recoil spring is not enough to push the slide forwards into the end position on its own. For that reason, support the slide's forward travel and push it all the way forwards.

1. Pull the slide back until you can tell whether there is a round in the chamber (*Fig. 54*).
2. Push slide all the way forwards.

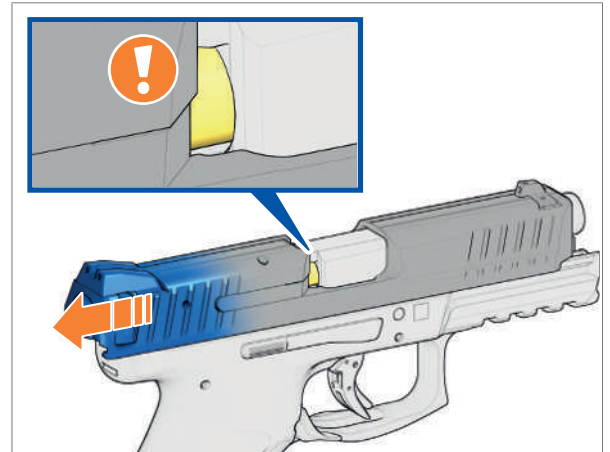

Fig. 54: Pull slide back

8.4 Firing position and aiming

8.4.1 Firing position



The two-handed grip is the most stable firing position and offers the prospect of the best possible hit results.

WARNING

Risk of injury when the slide snaps back!

During firing, the slide can cause serious injuries, especially to hands and fingers.

› Keep your hands out of the path of the slide when firing.



Fig. 55: Two-handed grip

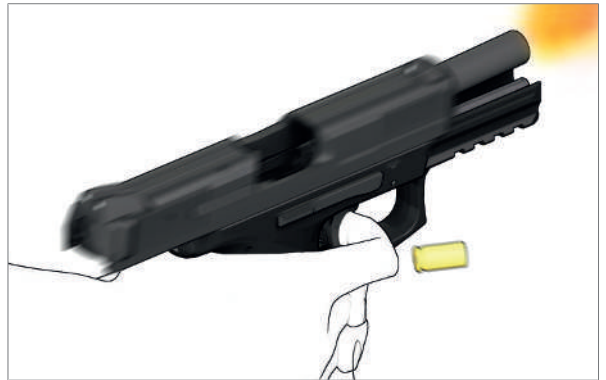
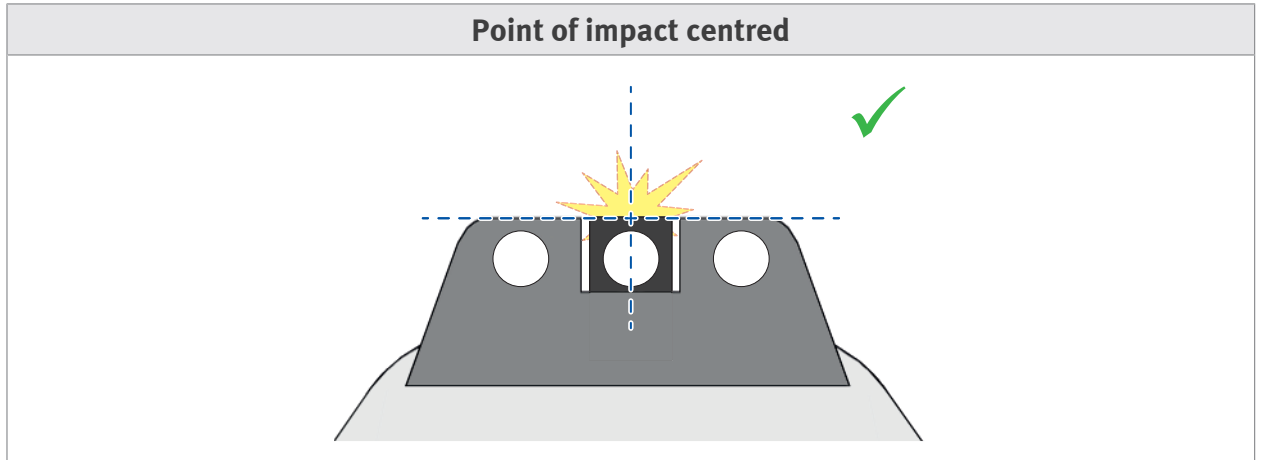

Fig. 56: Path of the slide

8.4.2 Aim

- Correct aiming



- Aiming errors

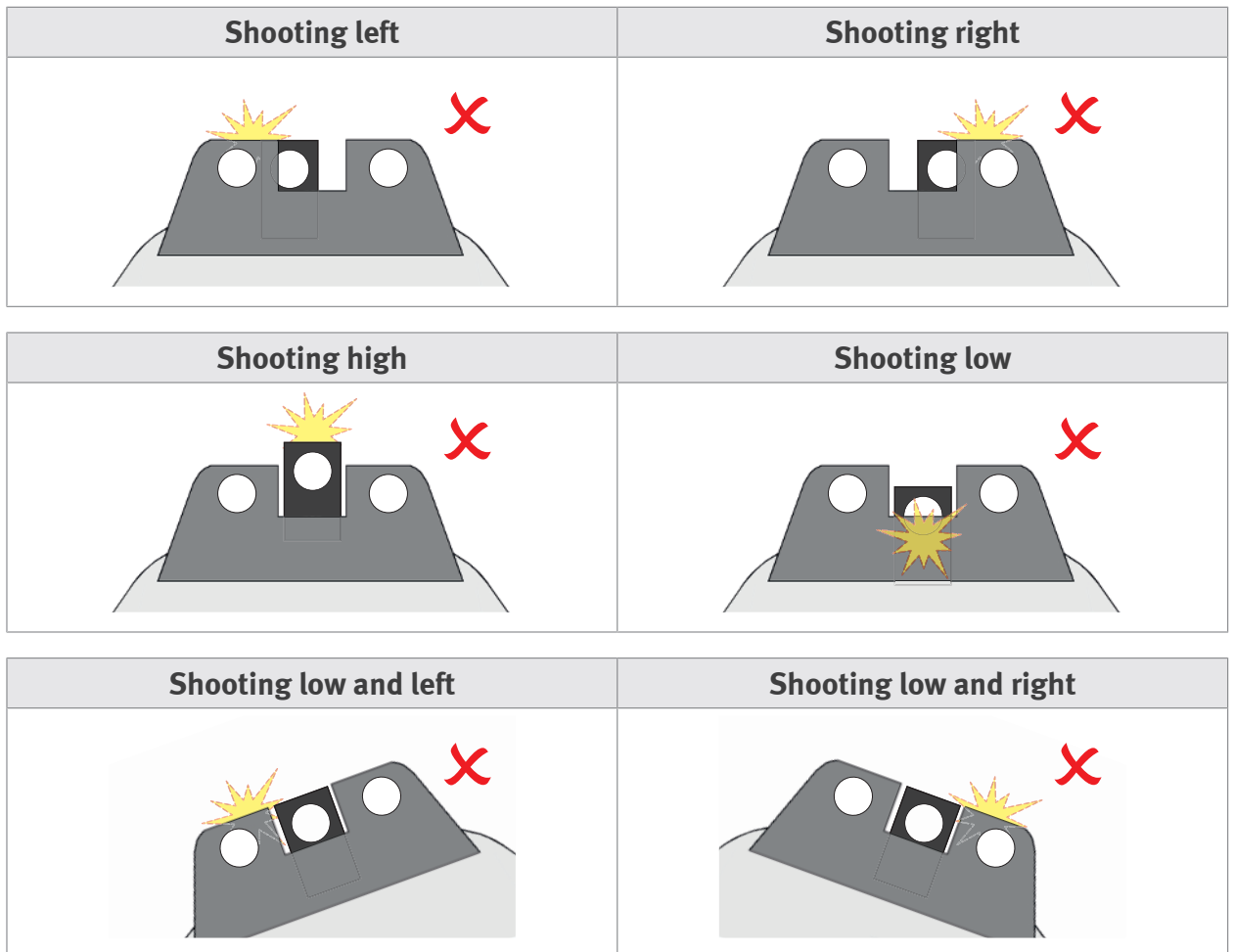

8.5 Firing



Follow ► Safety instructions for firing.

1. ► Prepare weapon for firing.
2. ► Load the weapon.
3. ► Take up firing position.
4. ► Aim.
5. For variants with safety lever, click safety lever to the "F" position.

WARNING

Risk of injury when the slide snaps back!

During firing, the slide can cause serious injuries, especially to hands and fingers.

- › Keep your hands out of the path of the slide when firing.

6. Pull trigger. A cartridge is fired.
7. For variants with safety lever, click safety lever to the "S" position.

8.6 Remove magazine

NOTICE

Risk of material damage from dropping the magazine!

Dropping a magazine can damage the magazine lips and cause malfunctions.

- › Remove the magazine by hand.
- › Avoid impacts on the magazine lips.

1. Hold your hand under the magazine.
2. Press magazine catch (Fig. 57).
3. Remove magazine (Fig. 57).

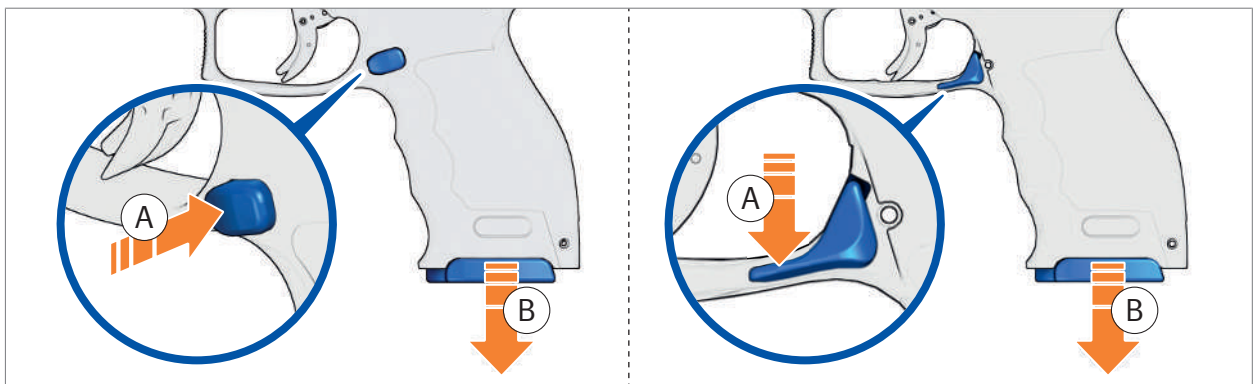

Fig. 57: Remove magazine

8.7 Reload weapon

⚠ WARNING

Risk of injury from accidental discharge of weapon!

A loaded weapon is always a potential source of danger.

- › Load the weapon only immediately before firing.
- › Unload the weapon immediately after firing.



After the last cartridge in the magazine is fired, the slide release holds the slide in the open position.

1. ▶ Remove the magazine.
2. ▶ Load the weapon.

8.8 Unload weapon

1. ▶ Remove the magazine.

⚠ WARNING

Risk of injury from igniting the cartridges!

Impacts to the primer can ignite the cartridge.

- › Only unload the weapon over a soft surface.
- › Prevent any impacts to the primer.
- › Prevent cartridges from falling.

2. ▶ Lock slide. A cartridge is ejected.
3. Look into the chamber. There must not be a cartridge in the chamber. If there is a cartridge in the chamber, then a fault is present. ▶ Faults: Causes and remedies.
4. ▶ Let slide snap forwards.

8.9 Empty the magazine

⚠ WARNING

Risk of injury from igniting the cartridges!

Impacts to the primer can ignite the cartridge.

- › Push the cartridges into your hand when you empty the magazine.
- › Prevent any impacts to the primer.
- › Prevent cartridges from falling.

- › Push cartridges forwards out of magazine (*Fig. 58*).

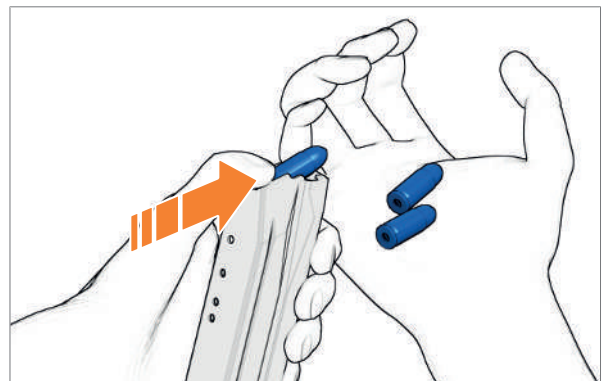

Fig. 58: Empty the magazine

9 Cleaning

9.1 General instructions for cleaning



Regular cleaning and care of the weapon and accessories

- maintain functional reliability,
- increase service life,
- prevent accidents, and
- save repair costs and time.

1. Clean weapon each time it is fired and at intervals of 1.000 rounds.
2. If heavily fouling ammunition is used: Clean and lubricate weapon at shorter intervals.

NOTICE

Risk of material damage from the use of excessive force!

The use of excessive force during cleaning can damage the weapon.

- › Do not use excessive force when cleaning the weapon.

9.2 Maintenance plan



The maintenance plan depicts routine tasks which must be conducted before or after firing, as well as after a certain number of rounds fired.

The following maintenance tasks are to be conducted according to the following table.

Symbols	Intervals
▲ = function check	V = before firing / use of the weapon
■ = cleaning / service point	N = after firing / use of the weapon
● = oil / lubrication point	S (100) = according to total of rounds fired (number of rounds)

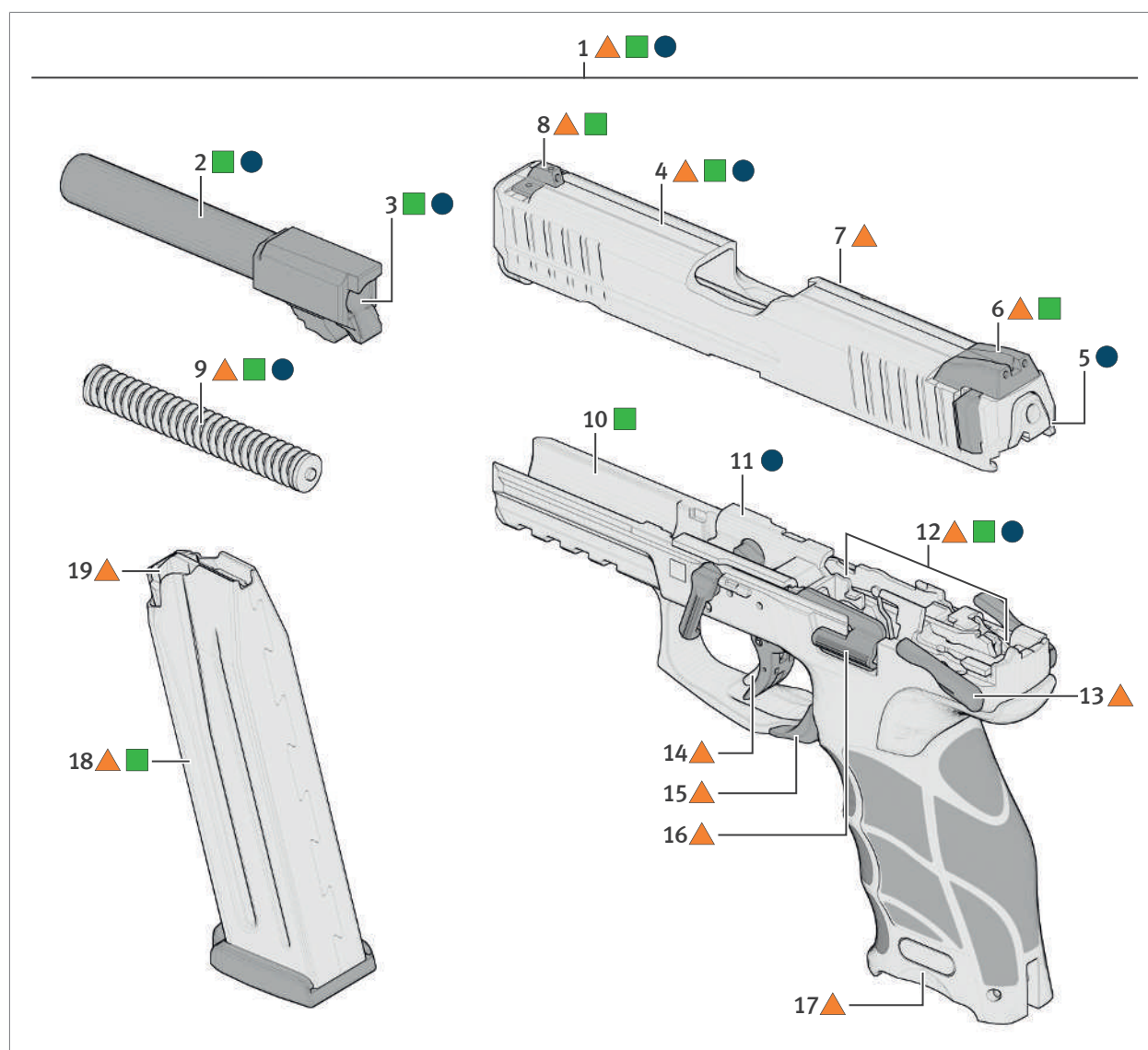

Fig. 59: Overview of maintenance points

Item	Designation	Check / activity	Auxiliary materials	Time of task
1	Weapon	▲ function	—	V, N
		■ clean	Cleaning kit	N
		● oil	Oil, e.g. S-761	N
2	Barrel	■ de-oil	Cleaning kit	V
		■ clean	Cleaning kit	N
		● oil	Oil, e.g. S-761	N
3	Chamber / cart- ridge guide	■ de-oil	Cleaning kit	V
		■ clean	Cleaning kit	N
		● oil	Oil, e.g. S-761	N
4	Slide	▲ function	—	V
		■ clean	Cleaning rag	N
		● oil	Oil, e.g. S-761	N
5	Guideways on the slide	● oil	Oil, e.g. S-761	V
6	Rear sight	▲ condition	—	V
		■ clean	Cleaning rag	N
7	Extractor	▲ function	—	V
8	Front sight	▲ condition	—	V
		■ clean	Cleaning rag	N
9	Recoil spring	▲ function, condition	—	V
		■ clean	Cleaning rag	N
		● oil	Oil, e.g. S-761	N
10	Frame	■ clean	Cleaning rag	N
11	Guide-rails on frame	● oil	Oil, e.g. S-761	N
12	Trigger / Trigger mechanism	▲ function	—	V
		■ clean	Cleaning rag	N
		● oil	Oil, e.g. S-761	N

Item	Designation	Check / activity	Auxiliary materials	Time of task
13	Safety lever	▲ function, locking into place	—	V
14	Trigger safety	▲ function	—	V
15	Magazine catch	▲ function	—	V
16	Bolt catch/release	▲ function	—	V
17	Magazine well	▲ condition	—	V, N
18	Magazine	▲ condition	—	V, N
		■ clean	Cleaning rag	N
19	Follower, Magazine spring	▲ free movement	—	V
—	Accessories	▲ condition	—	V
		■ clean	Cleaning rag, Brush, Oil, e.g. S-761	N

9.3 Disassemble weapon



The disassembly safety mechanism prevents a cartridge from being in the chamber while the weapon is being disassembled. The disassembly lever is blocked by the magazine and slide. The disassembly lever cannot be operated until the magazine is removed and the slide is locked. Removing the magazine ensures that a cartridge cannot be fed into the chamber. If there is a cartridge in the chamber, the cartridge will be ejected when the slide is pulled back. Consequently there can be no round in the chamber when the weapon is disassembled into assembly groups. The firing pin is not cocked when the slide is being disassembled and the trigger must not be pulled.

WARNING

Risk of injury from improperly assembled weapon!

Improper assembly can compromise the safety and functioning of the weapon.

› Only disassemble the weapon to the extent described in this manual.

1. ► Carry out a safety check.
2. ► Lock slide.

⚠ CAUTION

Risk of injury when the slide snaps forwards!

The slide snaps forwards when slide release is pushed.

› Do not reach into the path of the slide.

3. Turn disassembly lever clockwise as far as it will go (*Fig. 60*).
4. Pull slide back and hold it (*Fig. 61*).
5. Move slide forwards slowly and push it from frame (*Fig. 61*).
6. Remove recoil spring from slide (*Fig. 62*).
7. Lift barrel, push forwards and remove from slide to the rear.

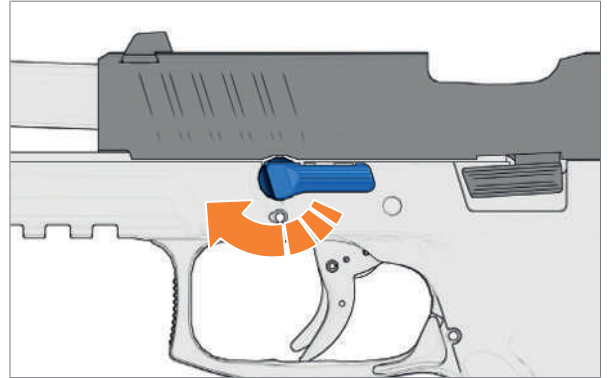

Fig. 60: Turning the disassembly lever

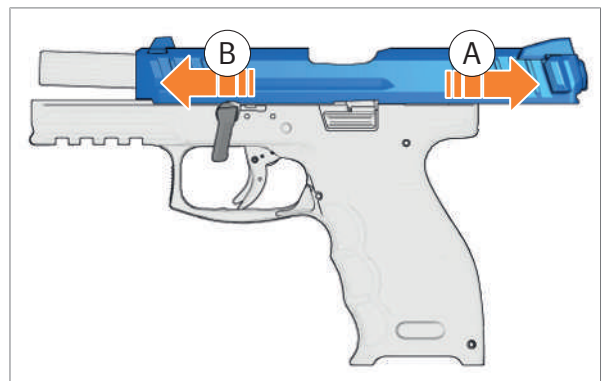

Fig. 61: Pushing slide from frame

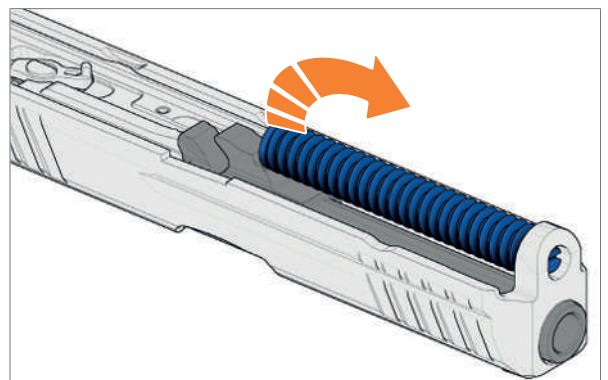

Fig. 62: Removing the recoil spring

9.4 Remove and insert disassembly lever (with SK variants)

As a rule, removing the disassembly lever and disassembling the frame are reserved for maintenance personnel. As a standard feature, the disassembly lever is secured by a spring to prevent it from falling out and, with SK variants, by the shape of the disassembly lever.

The disassembly lever can only be removed from the frame if:

- the weapon is disassembled into assembly groups,
- the trigger is pulled and held and
- the disassembly lever is in the disassembly position (*Fig. 63*).

Remove disassembly lever:

1. Disassemble weapon into assembly groups.
2. Pull trigger and hold it
3. Turn disassembly lever to disassembly position and remove it (*Fig. 63*).

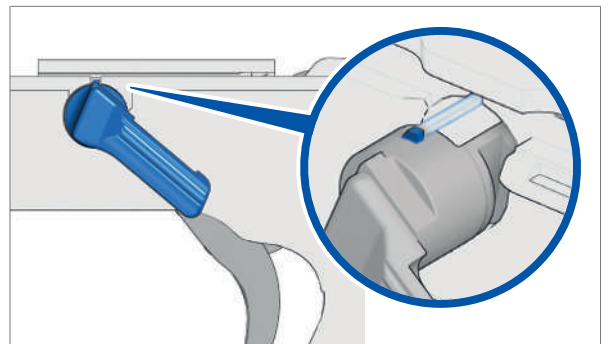

Fig. 63: Disassembly position

Insert disassembly lever:

4. Pull trigger and hold it
5. Put disassembly lever into disassembly position and insert it into the frame (*Fig. 63*).
6. Release trigger.
7. Turn disassembly lever clockwise. The weapon can be assembled.

9.5 Clean weapon

NOTICE

Risk of material damage from incorrect cleaning agents and care products!

Incorrect cleaning agents and care products can damage the weapon.

- › Exclusively use suitable cleaning agents and care products to clean small arms.
- › Do not use any metallic objects, plastic (nylon, etc.) or chemical cleaning agents (benzine, tetrachlorethylene, trichlor, etc.) to clean the weapon.

1. ► Disassemble weapon.
2. ► Clean assembly groups.
3. ► Clean slide.
4. ► Clean barrel.
5. ► Clean magazine.
6. ► Lubricate weapon.
7. ► Assemble the weapon.

9.5.1 Clean assembly groups

Required auxiliary materials:

- *Cleaning rag*
1. Clean fouled parts and surfaces using cleaning rag.
 2. Clean frame and slide using cleaning rag.
 3. Clean magazine well, magazine and follower using cleaning rag.
 4. Visually check weapon for damage.

9.5.2 Clean barrel

Required auxiliary materials:

- Oil
- Cleaning pull-throughs
- Cleaning kit

NOTICE

Risk of material damage from incorrect cleaning direction!

Cleaning the barrel from the muzzle end may damage the muzzle. A damaged muzzle will decrease the weapon's accuracy.

› Always clean the barrel starting from the chamber end.

1. Screw handle rod, extension rod(s) and barrel cleaning brush together.
2. Pull lubricated barrel cleaning brush through the barrel several times.
3. Replace barrel cleaning brush with pull-through holder.
4. Insert clean cleaning pull-throughs in pull-through holder.
5. Pull clean cleaning pull-throughs through barrel several times until barrel is free of oil and foreign bodies.
6. Replace cleaning pull-through with oil brush.
7. Pull lubricated oil brush through barrel.

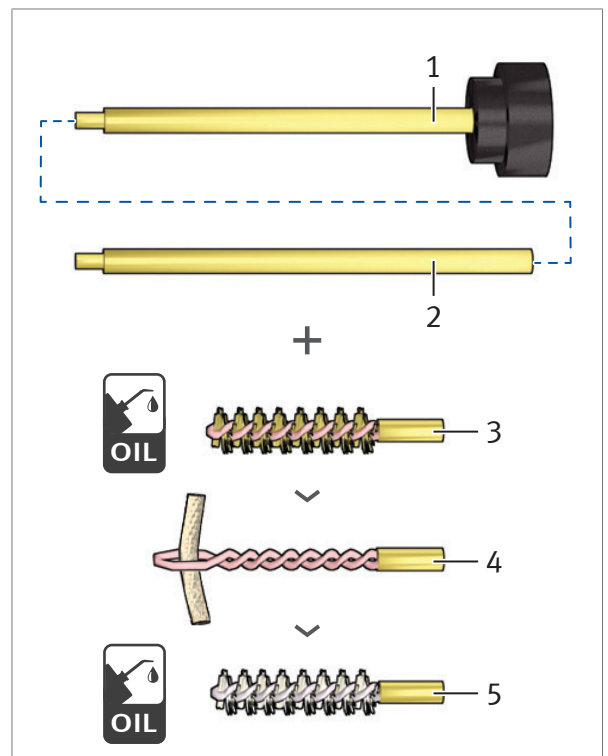

Fig. 64: Clean barrel

- 1 Handle rod
- 2 Extension rod
- 3 Barrel cleaning brush
- 4 Pull-through holder
- 5 Oil brush

9.5.3 Clean magazine

Required auxiliary materials:

- *Bottle cleaning brush (min. Ø 20 mm)*
- *Cleaning rag (lint-free)*
- *Detergent*

NOTICE

Risk of material damage from incorrect cleaning direction!

Cleaning the inside surfaces of the magazine lips with a bottle cleaning brush can damage the magazine lips. Damaged magazine lips impair cartridge feeding into the weapon.

› Clean the inside surfaces of the magazine from the bottom side of the magazine up to the magazine lips.

1. ► Disassemble magazine.
2. Rinse individual parts of the magazine with hot water and detergent.
3. Clean inside of magazine with bottle cleaning brush until no more dirt comes out of the magazine.
4. Dry cleaned individual parts of the magazine with a lint-free cleaning rag.

9.5.4 Clean slide

Required auxiliary materials:

- Oil bottle
- Cleaning rag



Depending on the ammunition type, the primer sealant may deposit in the firing pin bore. If the firing pin bore is heavily fouled, the cartridge will not ignite.

1. Place oil bottle on cleaning aperture.
2. Flush firing pin bore with oil until it is free of sealant (*Fig. 65*).
3. Remove excess oil with cleaning rag.

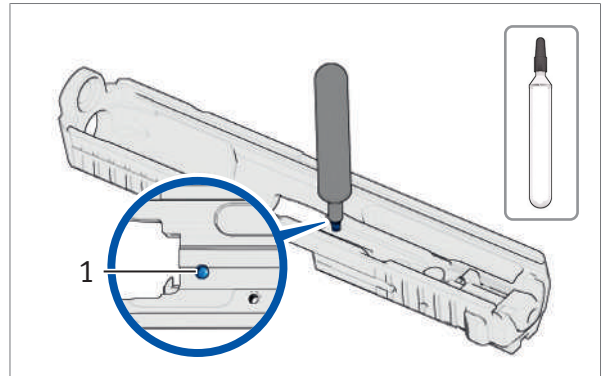

Fig. 65: Flush firing pin bore with oil

1 Cleaning aperture

9.5.5 Clean in ultrasonic bath

NOTICE

Risk of material damage caused by unsuitable settings and cleaning agents!

The paint on some parts may loosen off during cleaning the weapon in an ultrasonic bath. The weapon's functionality is not impaired by this.

- › Do not use any chemical cleaning agents (benzine, tetrachlorethylene, trichlor, etc.) to clean the weapon.
- › Use the specified parameters, settings and cleaning agents for cleaning in an ultrasonic bath.



Lubricate the weapon completely with oil after cleaning in an ultrasonic bath.

Clean in ultrasonic bath	
Cleaning frequency:	35 kHz
Water bath temperature:	50 - 70 °C
Cleaning time in ultrasonic bath:	10 - 15 min
Cleaning agent:	Customary washing up liquid

9.5.6 Lubricate weapon

Required auxiliary materials:

- Oil

1. Lubricate cleaned metal parts thinly.
2. Lubricate inside of slide, especially guideways.



If there is oil in the barrel when the weapon is fired, accuracy will be impaired and the barrel will be put under greater stress.

For that reason, see section:

► *Preparing the weapon for firing*

3. Lubricate outer bearing surface of barrel.
4. Lubricate the recoil spring guide rod.
5. Lubricate guide-rails on frame.
6. Clean magazine and follower using cleaning rag.

NOTICE

Risk of material damage from lubricated cartridges!

Lubricated cartridges result in increased loads on components and can damage the weapon.

- › Do not lubricate the inside of the magazine.

7. Lubricate outside of steel magazine thinly.



Once the weapon has been assembled: Pull the slide rearward several times so that the oil is distributed evenly.

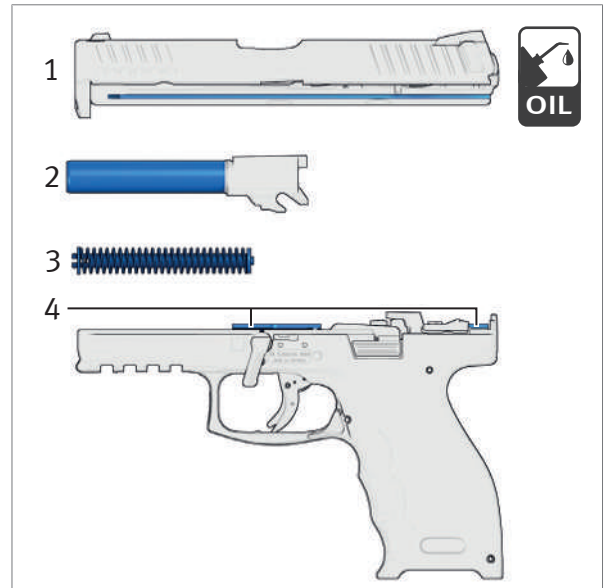

Fig. 66: Lubrication points

- 1 Guideways on the slide
- 2 Outer bearing surface of the barrel
- 3 Recoil spring guide rod
- 4 Guide-rails on frame

9.6 Assemble weapon

1. Place barrel into slide.
2. Push barrel to the rear until the barrel locks with the slide.



Note mounting position of recoil spring.

3. Insert recoil spring into slide (*Fig. 67*).
4. Brace recoil spring on the control surfaces on the barrel (*Fig. 68*). Note installation position of recoil spring (*Fig. 69*).

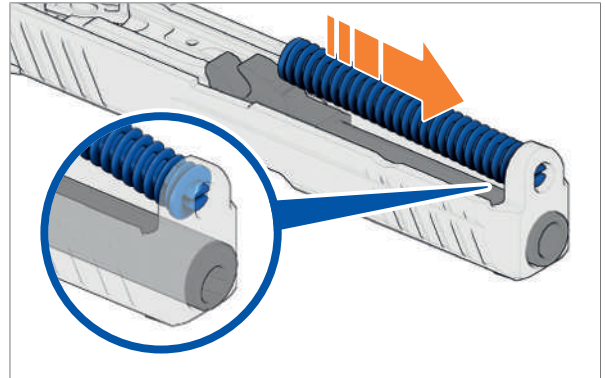

Fig. 67: Insert recoil spring

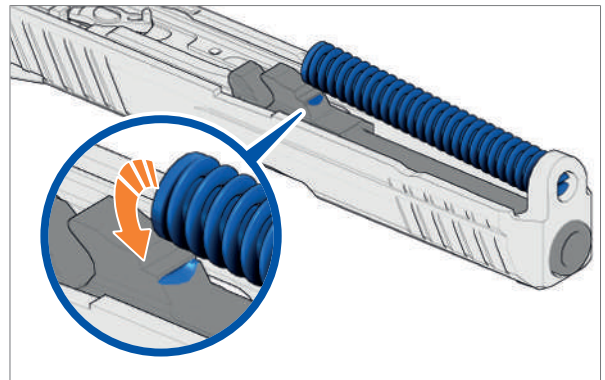

Fig. 68: Rest recoil spring

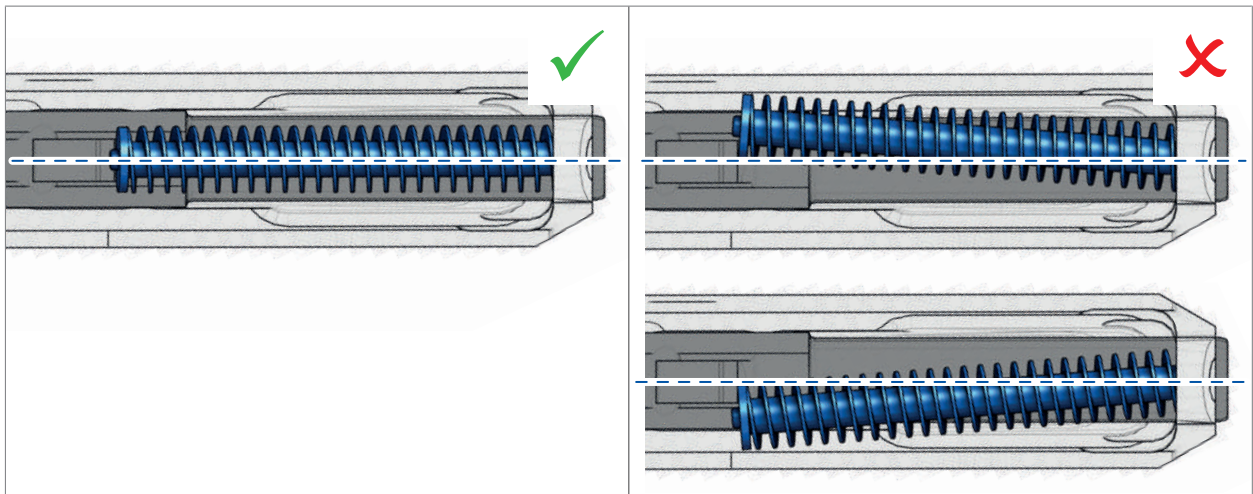

Fig. 69: Installation position of recoil spring

5. Place slide onto frame from above and push over the guide-rails of the frame (*Fig. 70*).
6. ► Lock slide.
7. Turn disassembly lever anticlockwise as far as it will go (*Fig. 71*).
8. ► Carry out a function check.

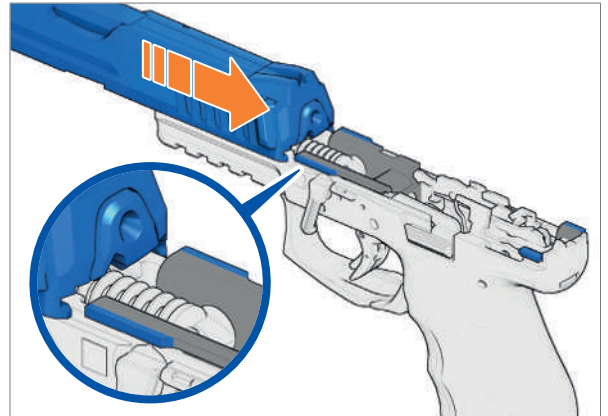

Fig. 70: Push slide over guide-rails

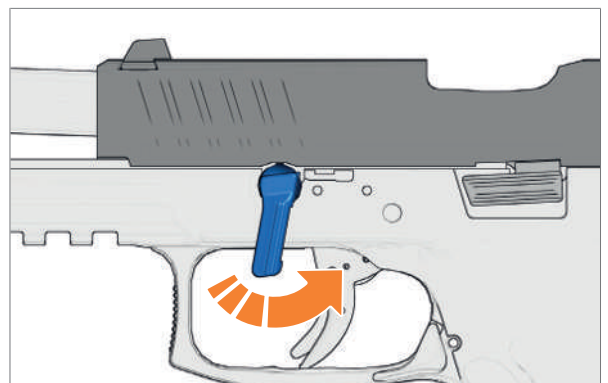

Fig. 71: Turn disassembly lever anticlockwise

9.6.1 Assemble magazine

1. Set follower onto magazine spring. Observe installation position (Fig. 73).
2. Place magazine spring onto magazine locking plate. Observe installation position (Fig. 73).

⚠ CAUTION

Risk of injury from spring-loaded parts!

The magazine spring is spring-loaded during assembly and can fly out of the magazine if the magazine spring is not secured.

- › Secure the magazine spring with your finger during assembly.

3. Press follower, magazine spring and magazine locking plate into magazine housing.
4. Push in magazine locking plate and hold it.

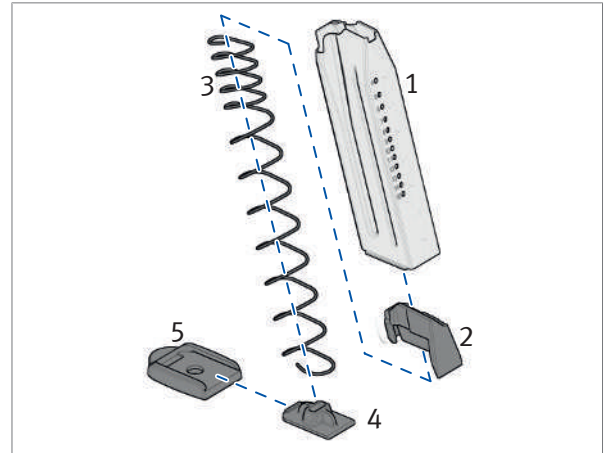

Fig. 72: Assemble magazine

- 1 Magazine housing
- 2 Follower
- 3 Magazine spring
- 4 Magazine locking plate
- 5 Magazine floor plate

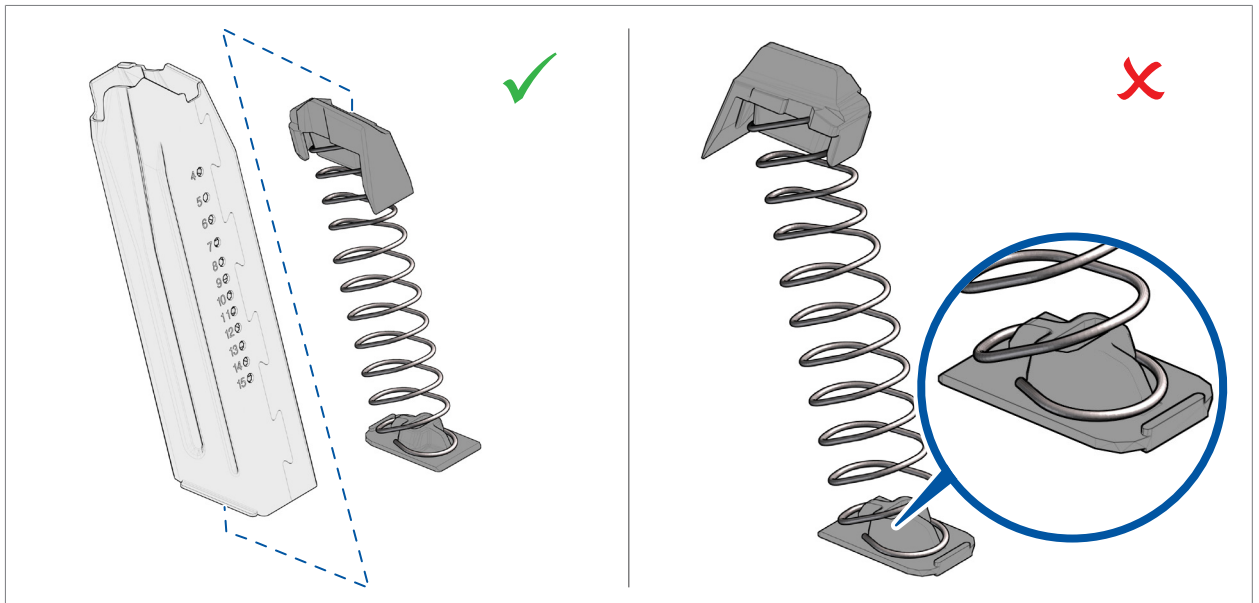

Fig. 73: Observe installation positions

- Slide magazine floor plate onto magazine housing from the front until the magazine locking plate engages in the magazine floor plate (Fig. 74).

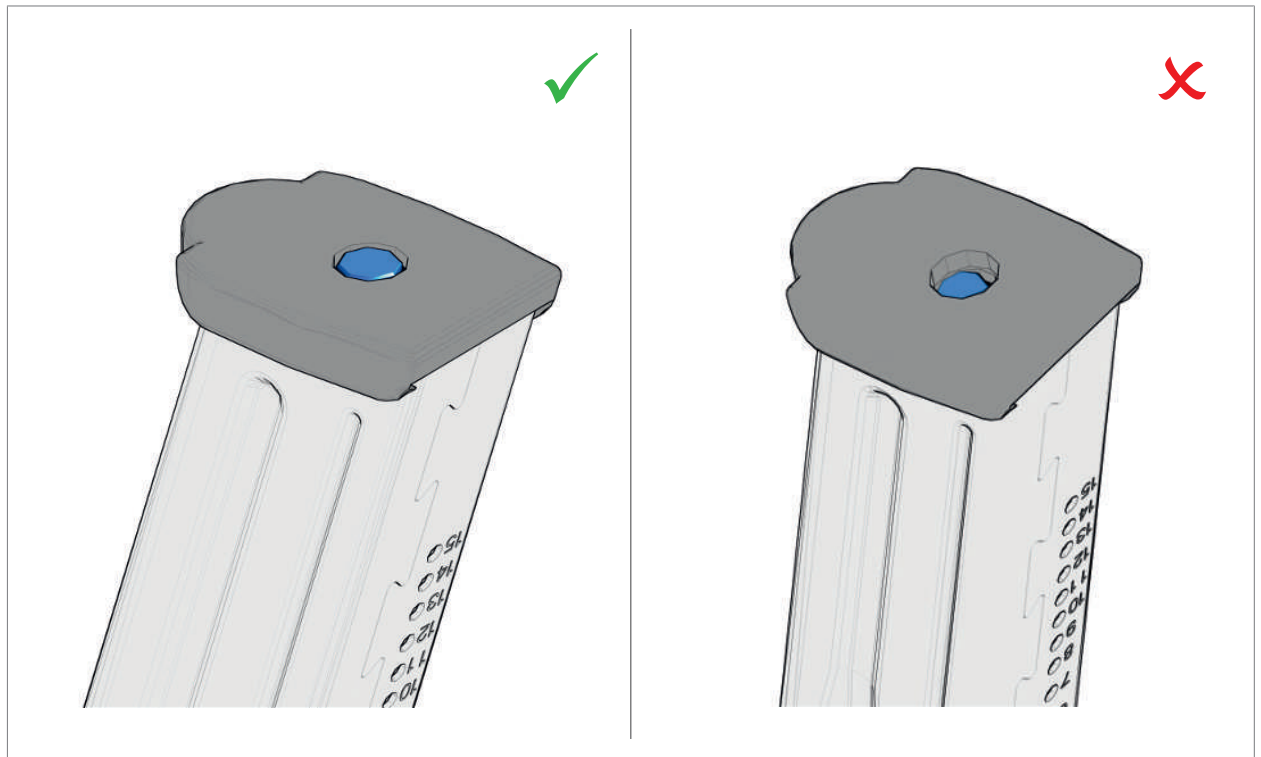

Fig. 74: Magazine floor plate assembly position/insertion

10 Faults: Causes and remedies



Users are strictly prohibited from troubleshooting faults that go beyond the scope of this manual! Only authorised specialists may rectify faults in the weapon.

WARNING

Safety risk from not knowing whether or not the weapon is loaded!

In the event of a fault, the weapon may be loaded even if you expect it to be unloaded.

- › In the event of a fault, treat the weapon as if it were loaded.
- › In the event of a fault, verify whether the weapon is actually loaded.
- › Follow the fundamental safety instructions for troubleshooting.

The following points do not constitute a complete list of all the possible faults. Faults/causes other than those named here are also possible.

Fault	Cause	Remedy
Weapon fires with unusually low impulse / weak recoil.	Defective ammunition. A bullet may be stuck in the barrel.	Check to make sure the barrel is clear. Send weapon in for repair if necessary.
Weapon fires with unusually high impulse / great recoil.	Defective ammunition. Barrel clearance was blocked by a foreign body / bullet during firing (barrel obstruction).	Send weapon in for repair.
Bullet is stuck in the barrel.	Defective ammunition.	Send weapon in for repair.
Firing pin is not released.	Shaped spring for trigger bar is defect.	Send weapon in for repair.
Bolt group does not open after firing.	Cartridge case deformed or chamber fouled.	▶ Unloading the weapon. Replace barrel if necessary. ▶ Cleaning the weapon. Send weapon in for repair if necessary.
	Defective ammunition	

Fault	Cause	Remedy
Cartridge has not ignited.	Firing pin bore in slide is soiled.	▶ Clean bolt group.
	Defective ammunition	Wait at least one minute. ▶ Unloading the weapon. Do not re-use cartridges that have failed to fire.
	Firing pin sluggish, damaged or broken.	Send weapon in for repair.
	Main spring sluggish, damaged or broken.	
Cartridge or cartridge case is not ejected.	Rearward movement of bolt group too short.	Check firing position. ▶ Unloading the weapon. ▶ Cleaning the weapon. ▶ Carry out function check.
	Defective ammunition	Use different cartridge. Do not re-use cartridge.
	Extractor, pressure spring for extractor and ejector damaged.	Send weapon in for repair.
Slide does not lock.	Cartridge case jams in ejection port (failure to eject).	▶ Carrying out a safety check. Remove cartridge, cartridge case or foreign body. Send weapon in for repair if necessary.
Cartridge is not loaded into the chamber.	Chamber fouled.	▶ Unload weapon. ▶ Clean weapon.
	Cartridge deformed.	Use different cartridge.
	Recoil spring defective.	Send weapon in for repair.

Fault	Cause	Remedy
Cartridge does not feed.	Magazine not correctly inserted.	Insert magazine correctly.
	Magazine spring defective.	Send magazine in for repair.
	Magazine or magazine lips damaged.	Use different magazine.
	Rearward movement of bolt group too short.	► Unloading the weapon. ► Carry out function check. Replace barrel if necessary. ► Cleaning the weapon. Send weapon in for repair if necessary.
Bolt does not stay in open position after last round.	Magazine spring defective.	Send magazine in for repair.
	Rearward movement of bolt group too short.	► Unloading the weapon. ► Carry out function check. Replace barrel if necessary. ► Cleaning the weapon. Send weapon in for repair if necessary.
	Slide release damaged.	Send weapon in for repair.
	Defective ammunition	Use different cartridge.
	Shaped spring for slide release defective.	Send weapon in for repair.
Position of the impact point shifted laterally.	Sights shifted.	► Adjust the sights. Send weapon in for repair if necessary.
	Other type of ammunition.	Use another type of ammunition or send weapon in for repair.
Position of the impact point shifted laterally.	Front sight damaged.	Send weapon in for repair.
	Other type of ammunition.	Use another type of ammunition or send weapon in for repair.

11 Protection, packaging and storage



Protection guards the weapon against external influences and maintains its functional reliability even if it is not used for long periods. Whenever the weapon is expected to be stored for more than 6 months, the weapon must be protected.

If the weapon is not expected to be stored for more than 6 months, it is sufficient to clean the weapon.

11.1 Protect the weapon

Required auxiliary materials:

- Grease
- Oil paper

1. ► Clean the weapon.
2. Seal both ends of the barrel with grease.
3. Wrap weapon in oil paper.

11.2 Package the weapon

1. ► Unload weapon.
2. ► Empty the magazine.
3. Package the weapon in appropriate transport container.

11.3 Store the weapon



Store the weapon and ammunition separately.

1. Follow applicable regulations for the storage of weapons and ammunition.
2. If the weapon is not expected to be stored for more than 6 months, it will suffice to clean the weapon. ► Clean weapon.
3. If the weapon is expected to be stored for more than 6 months, the weapon must be protected. ► Protect weapon.
4. ► Package weapon.
5. Store the weapon in an enclosed, weather resistant room.

WARNING

Risk of accidents caused by unauthorised persons!

Unauthorised persons who have no experience with weapons can cause accidents.

- › Be sure to prevent access to the weapon and ammunition by unauthorised persons, especially children.

6. Protect rooms where weapons are stored against break-in and fire.
7. If the weapon is to be stored for longer than 1 year, check the grease seal on the barrel and the oil film on the metal parts on an annual basis.

12 Transport and shipping

12.1 Prepare the weapon for transport

1. ► Package the weapon.
2. Secure weapon in vehicle.

NOTICE

Risk of material damage from vibrations!

Vibrations during transport can damage the weapon.

- › During transport, secure the transport container against slipping and damage from outside influences.
- › Avoid impacts and vibration of the weapon.

12.2 Transport and ship the weapon



Transport and ship weapon and ammunition separately.

- › Follow the applicable regulations on the transport and shipping of weapons and ammunition.



13 Destruction and disposal

13.1 Destroy the weapon

- › Follow the applicable regulations on the destruction of weapons and ammunition.

13.2 Dispose of the weapon

- › Follow the applicable regulations on the disposal of weapons and ammunition.

Index of keywords

A		D	
Additional information.....	9	Description of the features.....	20
Additional preparations in unusual climatic conditions.....	60	Description of the weapon	13
Adjust adjustable rear sight.....	54	Destroy the weapon.....	92
Adjust frame to hand	42	Destruction and disposal.....	92
Adjust magazine catch pushbutton.....	46	Differences between trigger variants TR and SF	23
Adjust rear sight	54	Dimensions [mm]	30
Adjust standard sights.....	55	Disassemble grip shells and back strap.....	42
Aim.....	65	Disassemble magazine catch	47
Assemble grip shells and back strap.....	43	Disassemble weapon	73
Assemble magazine	84	Disassembly safety.....	18
Assemble magazine catch	48	Dispose of the weapon	92
Assemble the adapter plate and the red dot sight	53		
Assemble weapon	82	E	
Assembly groups.....	16	Empty the magazine	68
Attach lanyard	44	Exclusion of liability and warranty.....	12
Auxiliary materials.....	33	Extreme cold (under -25°C) and snow	61
		Extreme dryness and heavy dust formation....	60
		Extreme heat	60
C		F	
Carry out a function check	38	Faults: Causes and remedies	86
Carry out safety check.....	37	Features for the product groups	20
Change charging supports	50	Features for the variants	21
Check whether there is a round in the chamber – "Chamber check"	63	Fill magazine with a loading aid.....	58
Checking function of the trigger safety	40	Fill magazine without a loading aid.....	57
Checks	37	Fill the magazine	57
Clean assembly groups.....	76	Firing	66
Clean barrel.....	77	Firing pin cocking indicator.....	19
Clean in ultrasonic bath.....	80	Firing pin safety	17
Clean magazine.....	78	Firing position	64
Clean slide	79	Firing position and aiming	64
Clean weapon.....	76	Functional elements	14
Cleaning	69	Fundamental safety instructions.....	7
Cleaning kit	31, 32		
Cleaning kit and auxiliary materials	31	G	
Conventions for cross references	6	General instructions for cleaning	69
Conventions for illustrations.....	6		

H		R	
Handing over the weapon	9	Reload weapon.....	67
Handling.....	8	Remove and insert disassembly lever (with SK variants)	75
I		Remove and insert front sight	49
Insert cover plate.....	52	Remove and insert rear sight	49
Insert magazine.....	62	Remove cover plate	51
Insert safety flag.....	45	Remove magazine	67
Inspect shaped spring for trigger bar	39	Remove safety flag	45
Intended use	14	S	
L		Safety features	9, 17
Let slide snap forwards.....	41	Safety instructions.....	7
Load weapon.....	62	Safety instructions and danger levels	4
Loaded chamber indicator	19	Safety instructions for drop safety	11
Lock slide	41	Safety instructions for firing.....	10
Lock slide and let slide snap forwards	41	Safety instructions for handling the weapon	8
Lubricants / Other auxiliary materials	34	Safety instructions for utilising accessories and ammunition	10
Lubricate weapon	81	Safety instructions, notes and information	3
M		Safety lever	19
Maintenance plan.....	70	Saltwater and salty air	61
Malfunctions and unusual encumbrances	9	SFP9 L – "Long Slide"	27
Moisture and mud	60	SFP9 M SFP40 M – "Maritime".....	29
O		SFP9 OR SFP40 OR – "Optic Ready"	28
Operation	62	SFP9 S SFP40 S – "Safety"	26
Operator safety.....	18	SFP9 SD SFP40 SD – "Silencer"	26
Optional features.....	22	SFP9 SK – "Subcompact"	27
Other data	30	SFP9-SF SFP40-SF – "Special Forces"	25
P		SFP9-TR – "Technical Specifications"	25
Package the weapon.....	89	Storage, transport and disposal.....	9
Preparations.....	41	Store the weapon	90
Prepare the weapon for transport.....	91	Symbols used.....	5
Prepare weapon for firing.....	59		
Protect the weapon.....	89		
Protection, packaging and storage.....	89		
Purpose of this manual.....	3		

T

Target audience for this manual.....	3
Technical data	30
The operator's manual as an integral component of the safety concept.....	8
Tools	33
Torque wrench and employment.....	33
Transport and ship the weapon	91
Transport and shipping.....	91
Trigger safety	17

U

Unload weapon	68
Use red-dot sight with OR variants	51
Using the safety flag	45
Using the weapon with a silencer.....	56
Using this manual.....	3

V

Variants.....	20
---------------	----

W

Weights [g]	30
-------------------	----

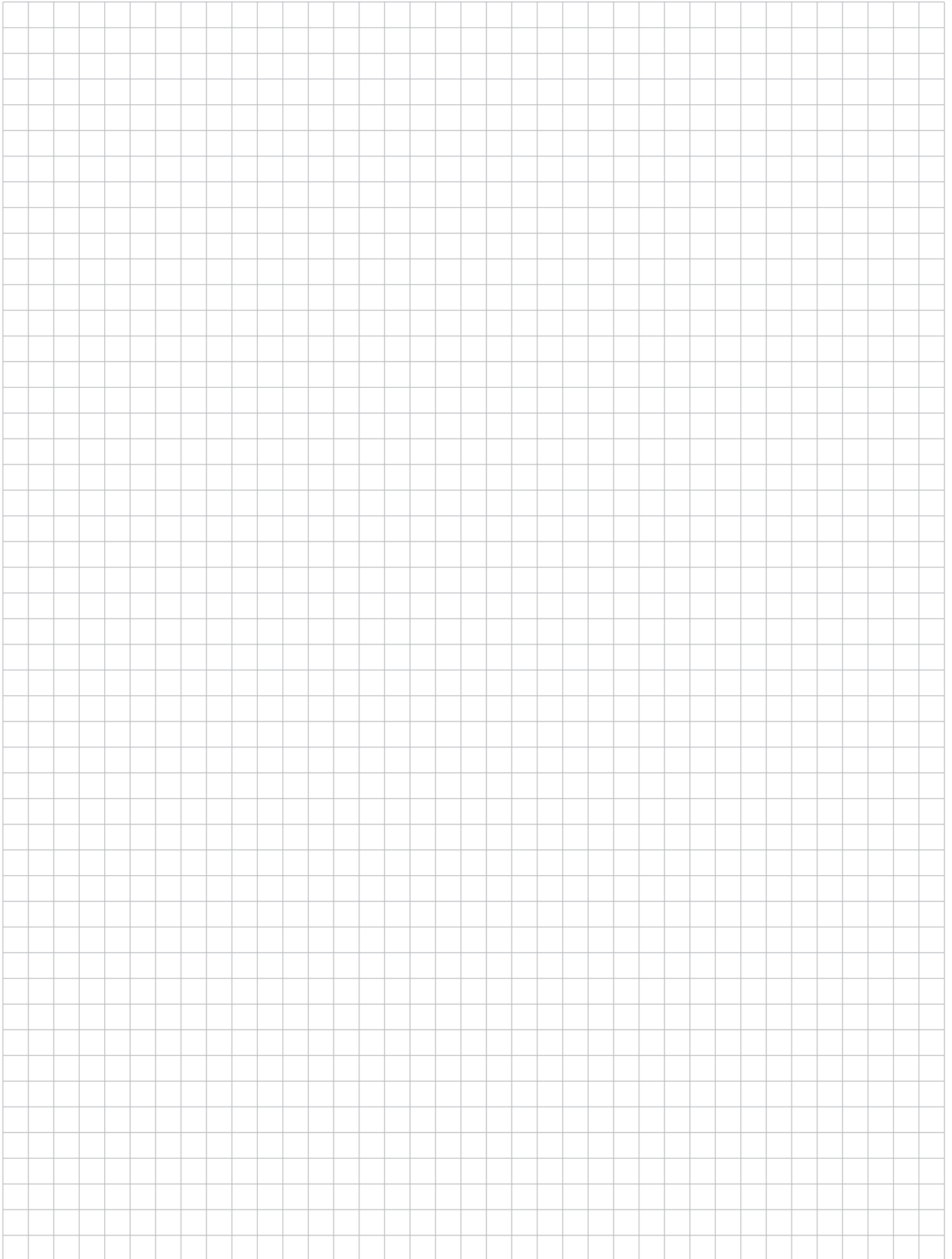

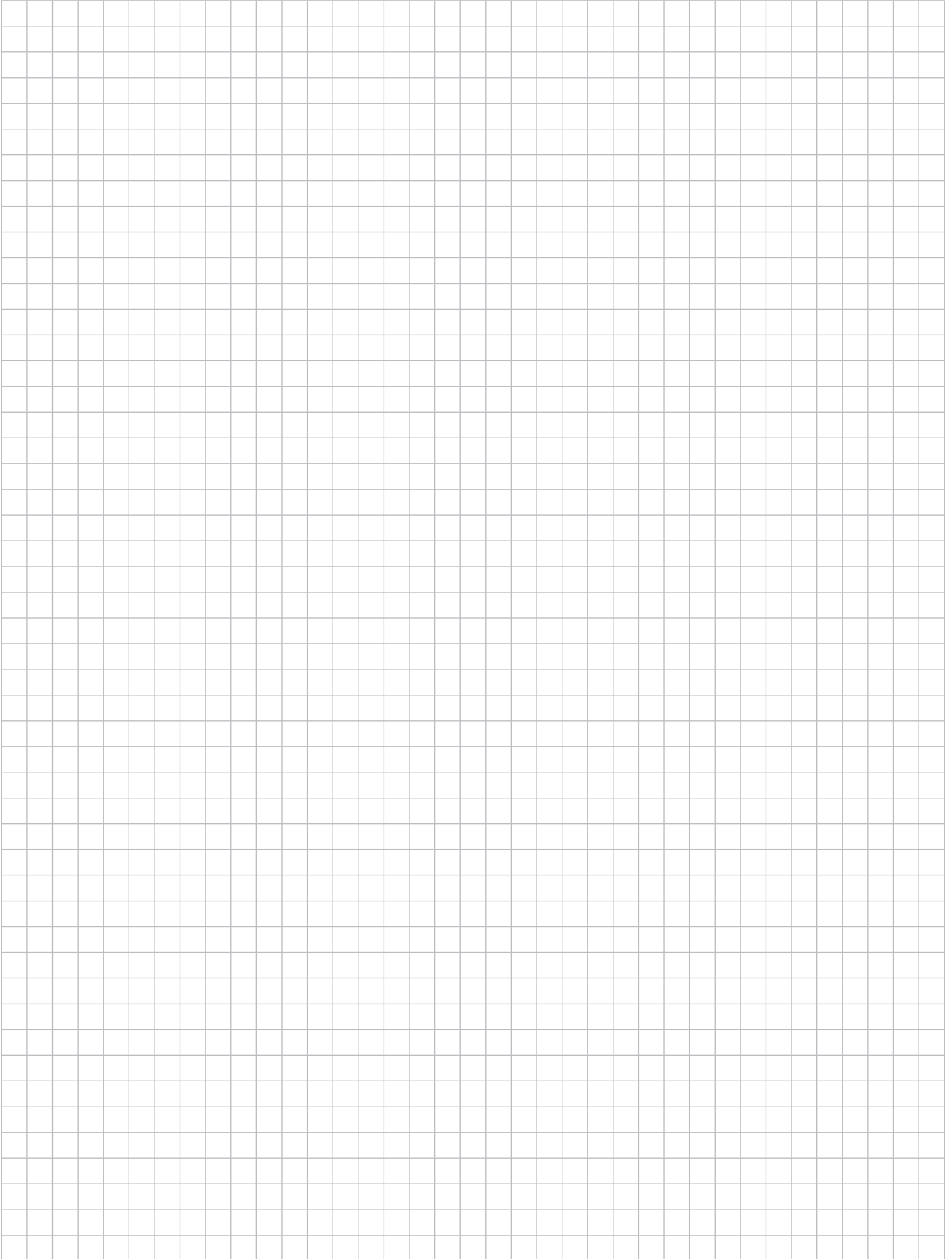

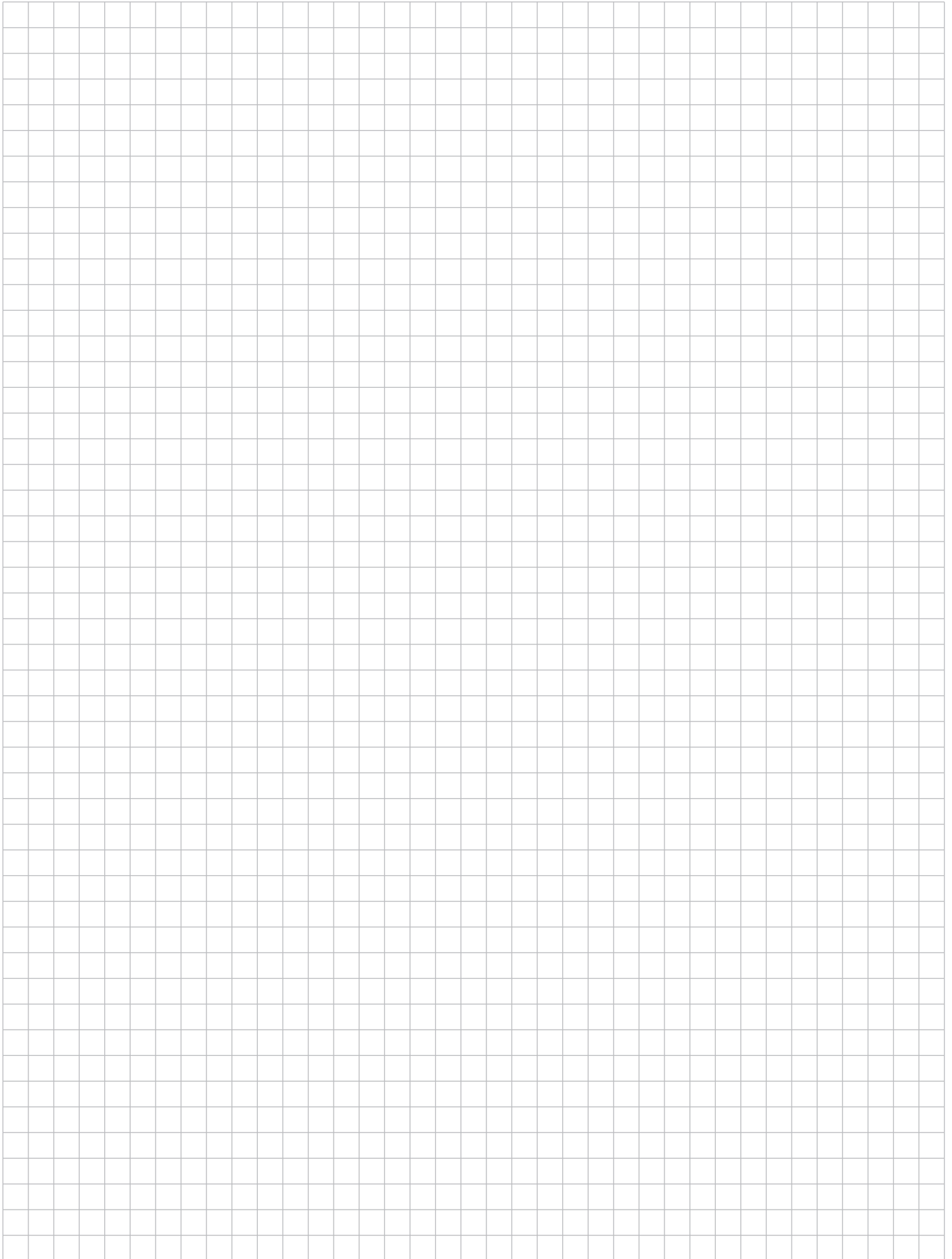

PISTOL	SFP9-TR	SFP9-SF	SFP40
Calibre	9 mm x 19		.40 S&W
Operating principle	Recoil-operated		
Locking system	Modified Browning locking system		
Trigger system	Single Action (SA)		
Magazine capacity	15 rounds	13 rounds	
Dimensions			
Length	186 mm		
Width	33 mm		
Height	138 mm		
Barrel length	104 mm		
Sight radius	162 mm		
Weights			
Weapon with magazine ₁	710 g	820 g	
Magazine, empty	93 g		
Other data			
Trigger pull	30+5 N	22+5 N	22+5 N
Trigger travel	11 mm / 5 mm ₂	6 mm / 3 mm ₂	6 mm / 3 mm ₂
Muzzle velocity -v ₀ -	360 m/s ₃ / 415 m/s ₄		295 m/s ₅
Muzzle energy -E ₀ -	518 J ₃ / 525 J ₄		505 J ₅
Barrel profile / twist	Hexagonal / right-hand		

₁ Magazine empty

₂ For strings of rapid fire, the trigger must not be released to return to the starting position.

₃ RUAG Ammotec (SX) Sintox Standard ammunition, calibre 9 mm x 19

₄ Police service cartridge: Action 4, calibre 9 mm x 19

₅ Remington UMC 180 gr. ammunition, calibre .40 S&W

TECHNICAL DATA



Heckler & Koch GmbH
Heckler & Koch-Str. 1
78727 Oberndorf/N., Germany

+49 (0) 74 23 / 79-0
+49 (0) 74 23 / 79-23 50

TD@heckler-koch-de.com
www.heckler-koch.com